

Coil Hook with Counterweight CERTEX

Product information



Coil hook for lifting and handling of coils and similar loads with a center of gravity below the tine while transport.

Design: Lifting eye, handle, rounded tine, counterweight (only for positioning the empty coil hook to improve balancing and positioning).

Note: The center of gravity of the coil must always be below the crane hook slightly toward the back of the coil hook. The tine tip will face upwards (ideally approx. 3°) to achieve an acceptable

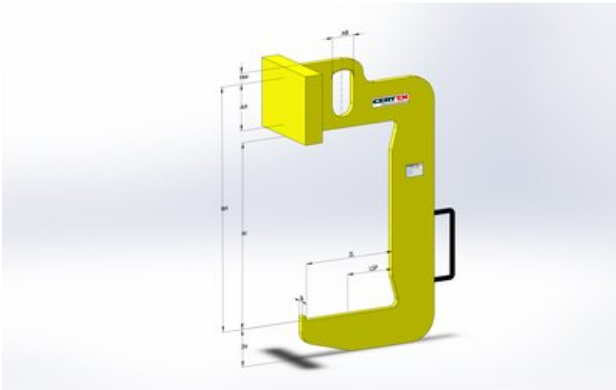

Part Code	WLL ton	AB mm	AH mm	BH mm	HM mm	IH mm	LSP mm	ZB mm	ZH mm	ZL mm	Weight kg	Delivery time
503500300000080	3	75	150	785	38	600	155	20	120	305	65	49
503500300000081	3	75	150	685	38	500	205	20	130	405	70	49
503500300000082	3	75	150	685	38	500	255	20	150	505	85	49
503500400000080	4	75	150	885	38	700	155	20	140	305	85	49
503500400000081	4	75	150	785	41	600	230	25	150	455	110	49
503500400000082	4	75	150	685	41	500	305	25	170	605	125	49
503500500000080	5	75	150	760	45	550	255	25	180	505	135	49
503500500000081	5	75	150	760	48	550	385	30	200	760	195	49
503500500000083	5	75	150	760	48	550	640	30	240	1,260	310	49
503500500000082	5	75	150	760	48	550	510	30	220	1,010	340	49
503500500000084	5	75	150	780	48	550	760	30	260	1,510	370	49
503500750000080	7.5	105	210	870	56	600	385	30	240	760	260	49
503500750000081	7.5	105	210	870	56	600	510	30	270	1,010	320	49
503500750000082	7.5	105	210	870	56	600	640	30	290	1,260	400	49

Blueprint

