

# OPERATING INSTRUCTIONS

Version 1 -



## Vacuum lifting device AERO /

Machine No.



*General drawing to illustrate the device structure. Dimensions of beams and suction plates as well as their number can vary and can be found in the offer / order.*

**Load bearing capacity: max/SWL/WLL \_\_\_\_\_ kg at 50% vacuum**



**Read carefully prior to start up!**

AERO-LIFT Vakuumtechnik GmbH  
Turmstraße 1 | 72351 Geislingen | Germany

E-Mail: info@aero-lift.de  
Tel.: +49(0)7428 / 94514-0  
Fax: +49(0)7428 / 94514-38

## Device configuration

The vacuum lifting unit is used for the **horizontal** and / or vertical transport of metal sheets or other inherently stable goods (dense and smooth surface) with a maximum weight of kg **(max. load bearing capacity depending on suction plate configuration, see Table).**

Product to be transported: Sheet metal blanks with an airtight and smooth surface  
 Dimensions of transported product: mm (L x W x H)  
 Weight of transported product: max. kg  
 Type of transport: **Horizontal** and / or vertical transport  
 Designed for indoor use. (+5 to 40°C)

The vacuum supply is ensured by a diaphragm vacuum pump, VAL 0,7T.

With automatic power saving function (automatic pump control)  
 Pump switches off at 74% vacuum and switches on automatically at 57% vacuum, ensuring a constant operating vacuum between 57% and 74%.

An additional lifting eye enables the lifting unit to also be used for the vertical transport of objects, e.g. when handling windows, etc. The load bearing capacity is reduced by 50%.

The compact AERO CUBE vacuum lifting unit is also available with other suction plates and thus optimally adapts to the respective job site and the product to be transported. The following suction plates are available for the vacuum lifting unit:

Suction plate	Dimensions	Max. bearing capacity	Net weight of entire device
AL 360G	Ø 360 mm	250 kg horizontal / 125 kg vertical	18 kg
AL 270R	Ø 270 mm	135 kg horizontal / 67.5 kg vertical	18.5 kg
AL 245M	Ø 245 mm	90 kg horizontal / 45 kg vertical	19.5 kg
AL 300M	Ø 300 mm	145 kg horizontal / 72.5 kg vertical	21.5 kg

### ATTENTION!



Prior to initial use, the new device must be charged for approx. **8 hours!**  
 Afterwards, check the voltage displayed on the meter of the vacuum lifting unit!  
**The indicator light must be green!**

If the device is not used, the batteries should be recharged every 4 to 6 weeks!

# Contents

<b>1</b>	<b>Device configuration</b> .....	<b>5</b>
<b>2</b>	<b>List of abbreviations</b> .....	<b>5</b>
<b>3</b>	<b>Safety instructions</b> .....	<b>5</b>
3.1	Target group .....	5
3.2	Application area and intended use .....	5
3.3	Explanation of safety instructions .....	6
3.4	Explanation of symbols .....	6
3.5	Operator obligations and liability .....	8
3.6	General safety instructions .....	8
3.7	Foreseeable misuse .....	10
<b>4</b>	<b>Technical specifications</b> .....	<b>11</b>
4.1	Temperature limits for suction plate seals .....	11
4.2	Vacuum generator (Vacuum pump) .....	11
4.3	Electrical voltage for vacuum pump .....	11
4.4	Control voltage for warning device .....	11
<b>5</b>	<b>Designation and explanation of individual components</b> .....	<b>12</b>
<b>6</b>	<b>Putting into service</b> .....	<b>13</b>
6.1	Leak detection test .....	13
<b>7</b>	<b>Operation</b> .....	<b>14</b>
7.1	Switch on vacuum lifting unit .....	14
7.2	Picking up load .....	15
7.3	Transporting loads .....	15
7.4	Lowering the load .....	16
7.5	Changing suction plates .....	16
7.6	Shutting-down of vacuum lifting unit .....	17
7.7	Warning and safety equipment .....	17
7.8	Checklist in case of malfunctions .....	19
<b>8</b>	<b>Maintenance and repair</b> .....	<b>20</b>
8.1	Instructions .....	20
8.2	Inspection and maintenance list .....	21
8.3	Replace the seal at the respective suction plate .....	22
<b>8</b>	<b>Spare parts list</b> .....	<b>23</b>
<b>10</b>	<b>Warranty</b> .....	<b>24</b>
<b>11</b>	<b>EU Declaration of Conformity</b> .....	<b>25</b>
<b>12</b>	<b>Annex</b> .....	<b>26</b>
•	Sheet metal overhang .....	26
•	Glass overhang .....	27
•	Electrical wiring diagram .....	28
•	Vacuum pump datasheet .....	36
•	Additional hazards occurring during operation of vacuum lifting unit: .....	37
•	Overview drawing of the different (optional) AERO CUBE versions .....	38

Dear Customer.

To prevent any material damage or even personal injury, **the instructions and rules** provided in this instruction manual **must be complied with** and your device must undergo **regular maintenance**. This also includes ensuring that the information here is read, understood and complied with in all aspects by all personnel who have to work with this vacuum lifting unit.

**The entire instruction manual must always be kept in close vicinity of the device. AERO-LIFT Vakuumtechnik GmbH assumes no liability whatsoever for any damage and/or malfunctions, which arise in connection with noncompliance of this instruction manual!**

We reserve the right to make technical changes that are intended to improve the vacuum lifting unit.

If you should have difficulties however, do not hesitate to contact us.  
We will do our best to help you as quickly as possible. Our address:

AERO-LIFT Vakuumtechnik GmbH  
Turmstraße 1 | 72351 Geislingen | Germany

e-mail: info@aero-lift.de  
Tel.: +49(0)7428 / 94514-0  
Fax: +49(0)7428 / 94514-38

## 1 Device configuration

See device configuration on the second page

## 2 List of abbreviations

Abbreviation	Definitions	Explanation
UVV	Accident prevention regulations	Maintenance service for accident prevention
AL	AERO-LIFT	

## 3 Safety instructions

### 3.1 Target group

These operating instructions have been written for persons, who as a result of their professional training, work experience and their current work activity have adequate technical knowledge to safely and competently use the vacuum lifting unit and who are able to read and understand the instructions.

### 3.2 Application area and intended use

This vacuum lifting unit is used exclusively for transporting dry, intrinsically airtight and slightly rough products, while taking into account the device's maximum load-bearing capacity and operating vacuum of at least 50%!

The vacuum lifting unit is **n o t** suited for use in closed rooms, in which there are particular hazards (e.g. risk of explosion).

Any other use exceeding the intended use is deemed as noncompliance. AERO-LIFT assumes no liability for damages resulting from such unauthorized use. Only the user of the vacuum lifting unit bears the risk.

#### NOTE

Not every warning device is equipped with red/green lights as standard. The control vacuum meter has a red/green range with the aid of which it is possible to optically determine the prevailing vacuum!

### 3.3 Explanation of safety instructions

#### Warning breakdown:

#### (1) SIGNAL WORD



(5)

(2) Signal word classifies the danger

(3) Explanatory text: Type and source of the danger + possible consequences

✓ (4) Measures or prohibitions to be taken

(5) Symbol: supporting graphical representation of dangers

#### Categorization of warnings:

#### DANGER!

Danger describes a dangerous situation. If appropriate measures are not taken, it will lead to serious injury or death.

#### WARNING!

Warns of a potentially dangerous situation. If appropriate measures are not taken, it may lead to serious injury or death.

#### ATTENTION!

Points out a potentially dangerous situation. If appropriate measures are not taken, it may lead to minor or moderate injuries.

#### NOTE

No risk of injury. Indicates possible damage to property and provides specific information.

### 3.4 Explanation of symbols







#### Warning signs:







Warns or indicates a hazardous area. Different symbols in the warning triangle explain a danger in more detail.











Warns of tipping over and serious injury due to crushing

 <p>Warns of dangers due to electrical voltage</p>	 <p>Warns of a suspended load</p>
 <p>Warns of serious injuries due to crushing of limbs and hand injuries</p>	 <p>Warns of falling objects</p>
 <p>Warning with regard to hot surfaces. Vacuum pumps become hot during operation.</p>	 <p>Warning of dangers from batteries</p>

**Mandatory action:**

 <p>Points out that you should pull out power plug</p>	 <p>Points out that you should wear protective shoes</p>
 <p>Points out that you should wear hearing protection</p>	 <p>Points out that you should wear gloves</p>

**Symbols:**

 <p>Vacuum level <b>less than 50%</b>: Device is <b>not</b> ready for operation</p>	 <p>Vacuum level <b>greater than 50%</b>: Device is ready for operation</p>
 <p>Read operating instructions prior to start-up</p>	 <p>Do not stand or walk under suspended loads</p>
 <p>Manual sliding valve to the left (to do so, hold down the safety lock) to <b>release</b></p>	 <p>Manual sliding valve to the right for <b>suction</b></p>
 <p>Button for release Both buttons must be pressed simultaneously!</p>	 <p>Button for suction</p>
 <p>Button for release and suction Both buttons must be pressed simultaneously!</p>	



The load capacity indicated on the nameplate may not be exceeded.  
Blocked suction plates reduce the load bearing capacity of the device.



Manual sliding valve red/green for individually lockable suction plates (optional)  
Red = blocked suction plate  
Green = suction plate not blocked

### 3.5 Operator obligations and liability

The operator/user is obligated:

- to only use the vacuum lifting unit when it is in fault-free state of repair.
- to immediately report to AERO-LIFT in writing any changes occurring to the vacuum lifting unit which could impair the safety.
- to constantly check the vacuum lifting unit for any apparent damage and/or deficiencies to immediately report in writing any changes noted, including operating performance.
- to comply with maintenance cycles.
- to immediately remedy or eliminate any faults that could have an adverse effect on safety.

### 3.6 General safety instructions

- The vacuum lifting unit may **only** be operated by trained personnel and maintained and repaired by authorized personnel.
- This instruction manual must be read and understood by **every person**, who works with this device.
- The vacuum lifting unit may only be used for the application described in the section "Application Area and Intended Use".
- Refrain from any activity or form of work that adversely affects the safety of the device or that puts your own safety or the safety of other persons or the machinery and systems at risk.
- Unauthorized modifications or changes, which impair the safety of the vacuum lifting unit, are not permitted. AERO-LIFT assumes no liability whatsoever for any resulting damages. **Only original AERO-LIFT replacement parts may be used.** AERO-LIFT assumes no liability whatsoever when parts from other manufacturers are used.
- Safety equipment may not be removed, deactivated or rendered unoperational.
- In case of a sudden loss of vacuum, the load must be **immediately** lowered or secured against dropping.
- The operation of the vacuum lifting unit is subject to the applicable local safety and accident prevention regulations.



**DANGER!**



**Electrical voltage!**

Do NOT open the housing when the device is energized. Can cause death, burns and property damage.



- ✓ Regular visual inspection of electrical lines and housing / cover for external damage.

**DANGER!**



**Suspended loads!**

A power outage, incorrect pick-up, premature release, pick-up of an excessive load or a collision during transport can cause the load to become loose from the vacuum lifting unit or to fall and cause serious injuries or even death.



- ✓ Do NOT stand under suspended loads and do not climb on suspended loads.



- ✓ Persons may NOT stay in the transport area.

- ✓ Always make sure that the vacuum reading is over 60%.

- ✓ The load must be lowered or put down immediately if the red warning light lights up on the warning module or an alarm sounds or the vacuum falls below 60%!



- ✓ Do NOT place loose objects on loads that are to be lifted.



**WARNING!**



**Moving parts!**

Persons can get hurt by the moving parts of the vacuum lifting unit. In the range of the unit's movement, persons may be bumped, hit or injured by the lifting device.



- ✓ Persons may NOT stay in the transport area.

- ✓ The operator must observe his or her duty to supervise during operation.



**WARNING!**



**Hot parts - risk of burns!**

Persons can burn themselves on the vacuum pump, since it gets hot after a long period of use.

- ✓ Regularly clean air supply/filter

**NOTE**

If present, the hose anchoring system shall be selected and/or configured in such a way that the hoses running to the suction plates are routed over a semi-circular bend. The hose must be routed in a straight and taut manner up to the hose connection, in this regard see Basic setup, which have already been marked by AERO-LIFT.

**3.7 Foreseeable misuse**

The machine is **NOT** intended for the following applications:

- Handling of other components or variations than those approved by the manufacturer.
- Overstepping of maximum load bearing capacity
- Shutting off the suction plates that fall below the load bearing capacity.
- Load picked up out of center.
- Product to be transported are approached at an angle when being picked up.
- Storage of suction cup with suction cup facing down.
- Use in closed rooms with particular dangers (e.g. risk of explosion).
- Operation by untrained personnel.

The vacuum lifting unit may **NOT** be used to lift a load:



when the device is switched off.



when the LED is red instead of green.

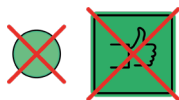

when the green LED does **not** light up.

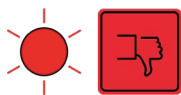

when the red light is on.



when the needle of the vacuum gauge is in the red range.

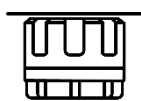

when the siren is sounding.



when the vacuum loss is greater than 5% within 5 minutes.

## 4 Technical specifications

For load bearing capacity: see cover page

### 4.1 Temperature limits for suction plate seals

Depending on the material characteristics of the suction plate seals, there are different temperature limits for the workpieces that are to be transported:

Material of suction plate seal:	Temperature limits:
Perbunan black	-20°C to +80°C
Perbunan gray	-20°C to +80°C
Perbunan white	-20°C to +80°C
Silicon transparent or red	-30°C to +180°C
Foam rubber HO / cellular rubber	-10°C to +70°C

The indicated temperature values relate to an indefinite contact period with the workpiece.

### 4.2 Vacuum generator (Vacuum pump)

Type:	VAL 0.7
Motor output:	32 W
Suction capacity in cbm/h:	0.7 cbm/h
Max. end vacuum:	75% (depending on location above sea level)
Operating voltage:	24 V DC
Compressed air consumption:	No compressed air is required.
Noise level	< 70 dB (A)

### 4.3 Electrical voltage for vacuum pump

Alternating current	24 V AC
---------------------	---------

### 4.4 Control voltage for warning device

Direct current	24 Volt
----------------	---------

## 5 Designation and explanation of individual components

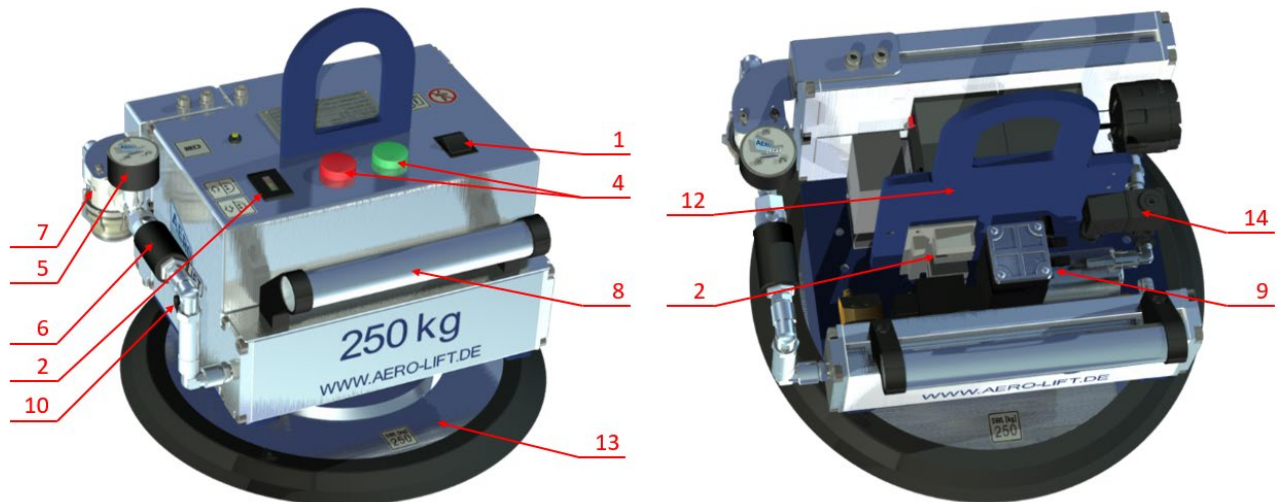

No.:	Designation:	Function:
1	Main switch	ON / OFF switch for operation.
2	Voltmeter	Display for checking the charge of the battery
3	Acoustic alarm	Acoustic warning in case of loss of vacuum
4	LED red / green	Optical warning signal in case of loss of vacuum / operational readiness
5	Vacuum control meter	Mechanical monitoring of vacuum. Including red/green lights for quick indication of vacuum level
6	Vacuum valve	Manual sliding valve (installed directly on the manipulation handle, see figure under 6.1), solenoid valve or pulse valve for the "Suction - Release" function
7	Vacuum filter: if necessary, water separator	Separation of particles and dirt to protect the vacuum generator. Absorption of unwanted water via the suction plates.
8	Manipulation handle	For handling and protecting the device against impact
9	Vacuum generator	Generation of vacuum in the vacuum accumulator (in housing, not shown)
10	Charger socket	Socket for connecting the external charger
11	Vacuum hose	Connection between vacuum distributor and suction plates (not shown in the drawing)
12	Suspension frame	Support of suction plate and components

13	Suction plate	Sealing of vacuum vis-a-vis the product to be transported
14	2-2-way valve	Closes the connection between the vacuum pumps and vacuum accumulators when they are not in use.

## 6 Putting into service

The device is delivered complete and ready for connection with battery charging cable. The external charger can be plugged into the charger socket (10). Prior to start-up, the vacuum lifting unit shall be inspected for completeness and possible transport damages. Any possible transport damage must be reported immediately in writing!

Prior to start-up, it is necessary to carry out a test run as described in "Operation" section.

Check the voltage of the battery using the voltmeter (2).

**The LED on the display must be green before putting the device into service.**

### 6.1 Leak detection test

Our company performs a 100% quality assurance and functional testing of the delivered vacuum lifting unit.

For safety reasons we still request that you inspect the device for any possible transport damage prior to start-up. In this case, it is also necessary to check for any possible leaks.

#### Performance of leak detection test:

1. Place the vacuum lifting unit on a flat dry nonporous workpiece (e.g. sheet metal or glass panel).
2. Switch on the vacuum pump at the main switch (1) and wait a moment for sufficient vacuum to build up in the accumulator.
3. Set the vacuum valve to the "Suction" position. The vacuum control meter (5) shows the exact negative pressure or vacuum (see 6.2 / 6.3).
4. The vacuum pump is now switched off at the main switch (1).
5. The indicator of the vacuum control meter (4) may not show more than 5 % vacuum loss for every 5 minutes.

If the vacuum loss should exceed the 5 % per 5 minutes limit, it is necessary to check the hose connections and tighten the hose clamps if applicable. The condition of the suction plate (13) must also be checked. The seals may not have any cracks or other signs of damage. The suction plate (13) must be clean and free of any oil or grease.

**Loss of vacuum may NOT exceed 5 % for every 5 minutes.**

#### NOTE

If there is a visible loss of vacuum > 5 % within 5 minutes that you cannot rectify, contact us promptly. Our specialists will help you immediately.

## 7 Operation

Install and remove the vertical lifting eye.

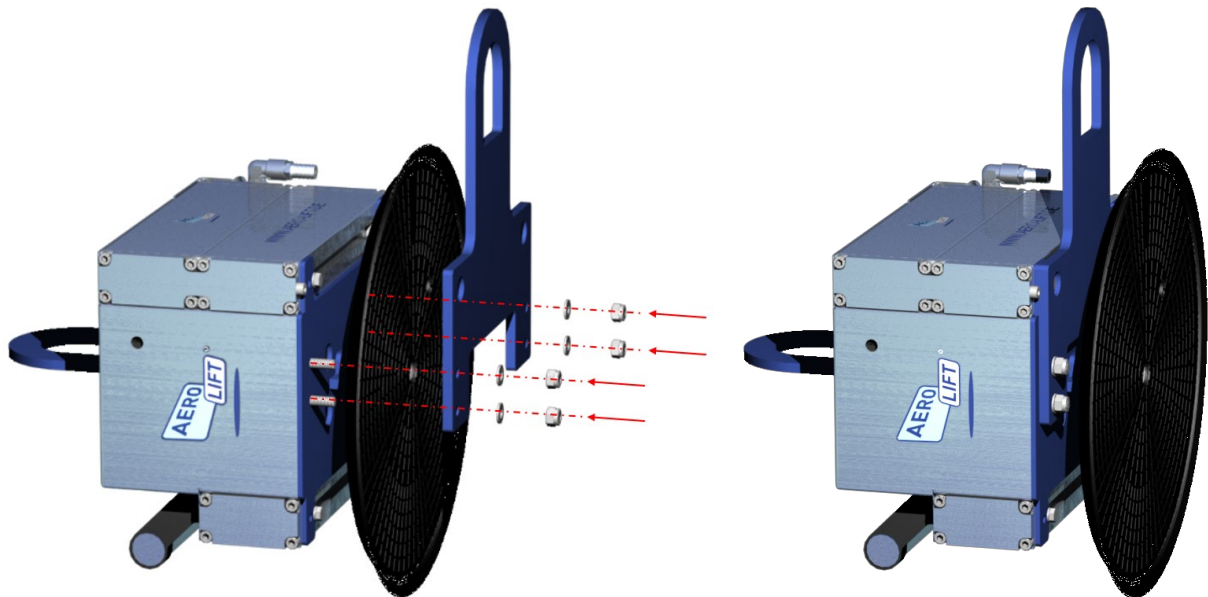

Place the vertical lifting eye on the existing stud bolts and secure with a washer and lock nut.

### 7.1 Switch on vacuum lifting unit

Switch on the vacuum lifting unit using the main switch on the warning module. Wait a moment until the possibly sounding acoustic alarm shuts off. A sufficient vacuum of more than 50 % was generated in the vacuum accumulator during this time.

The vacuum pump automatically switches on and off, ensuring that the vacuum level remains constantly between 57 % and 74 %. The vacuum pump usually runs for approx. 30-60 seconds. The battery will discharge faster if the vacuum pump runs longer! In such case, there is a possible leak between the suction plates and the material being transported or at the device itself!

#### NOTE

In case of large metal sheets it is important to note that the outer suction plates are situated at the ends of the traverses. Always make sure that there is sufficient safety clearance between the edge of the seal and the edge of the metal sheet!

#### NOTE

Depending on the sheet thickness, the sheet metal overhang may not exceed the dimensions indicated in the diagram (see annex "Sheet metal overhang").

## 7.2 Picking up load

- Use the crane to place the vacuum lifting unit on the product to be transported.
- Switch to the vacuum valve to "Suction". The product to be transported is suctioned and can be raised and transported with the device, as soon as the vacuum gauge indicates more than 50 %.

The load bearing capacity of the respective suction plate can be found in the annex.

### WARNING!



#### Falling loads!

Incorrectly picking up the load can cause the load to break away from the suction plates, thus possibly injuring people.

- ✓ The load may only be picked up centrally and at its center of gravity.
- ✓ Always make sure that the vacuum reading is over 50 %.
- ✓ Pay attention to the permissible load bearing capacity!

## 7.3 Transporting loads

The load can be transported to the desired location with the aid of the crane control system.

### DANGER!



#### Falling loads!

Persons can be injured by falling or moving parts during transport.



- ✓ The load must be lowered or put down **immediately** if the red warning light lights up on the warning module or an alarm sounds or the vacuum falls below 50 %!
- ✓ During the crane movement with the product to be transported, it is necessary to always make sure that the said material never bumps against a wall or any other objects.
- ✓ A load may only be moved when the device is switched on.
- ✓ Never walk under a suspended load during transport!

### WARNING!



#### Moving parts!

In the range of the lifting unit's movement, persons may be bumped, hit or injured by the lifting device.



- ✓ There may not be any persons or objects in the area of transport.

## 7.4 Lowering the load

(See section on “Device configuration”)

Use the crane to move the vacuum lifting unit to the desired position and lower the load. Once the load is stable or secure, the vacuum valve can be set to “Release”. The suction plates are ventilated now and the load is released immediately.

### WARNING!



#### Falling loads!

Prematurely releasing a load before it is fully resting can cause it to fall or slide and thus cause serious injury.

- ✓ When putting down the load, it is important to make sure that the load is resting fully and cannot tip over or slide.

## 7.5 Changing suction plates

Possibly you have several suction plates for this vacuum device..

For changing the suction plate, you have to disconnect the house from the suction plate (or possibly only disconnect the coupling system), then remove the four screws and remove the suction plate.

For assembly of the another suction plate please go threw in reverse order.

Please take care that the spring rings are below the screws and fix the screws with a torque of 21 Nm.

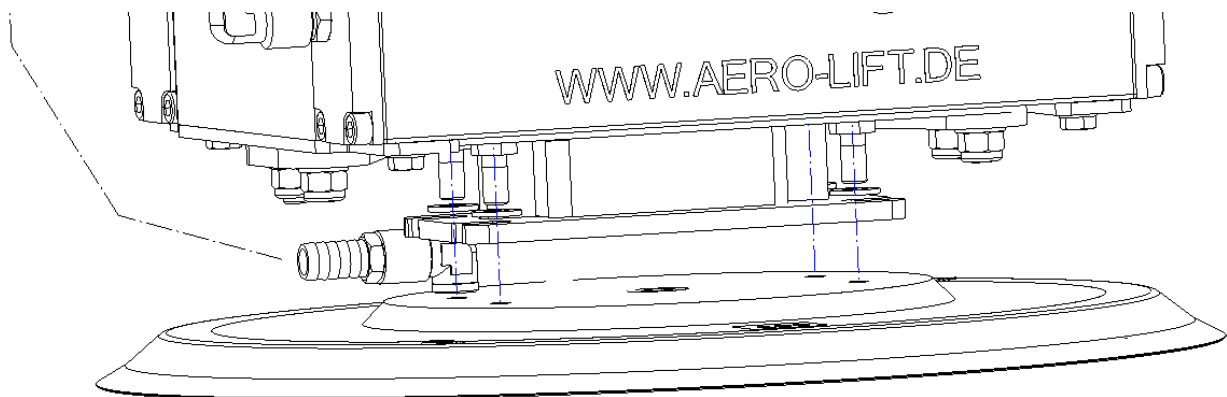

Take care on the max. load capacity of the suction plate!

### WARNING!



#### Falling loads!

Prematurely releasing a load before it is fully resting can cause it to fall or slide and thus cause serious injury.

- ✓ When putting down the load, it is important to make sure that the load is resting fully and cannot tip over or slide.



## 7.6 Shutting-down of vacuum lifting unit

To stop the device temporarily, use the main switch to turn off the vacuum pump. Leave the vacuum lifting unit attached to the crane so that the suction plates hang freely. If that is not possible or if the vacuum lifting unit will not be used for a longer period of time, then it should be placed on supports so that the suction plates can hang freely without being damaged.

### ATTENTION!



- ✓ Check the unit for stability and self-support before detaching it from the load hook
- ✓ Never allow the device to rest on the suction plates

## 7.7 Warning and safety equipment

### Vacuum control meter:

The vacuum lifting unit possesses a vacuum control meter, which is installed in an easy-to-read location on the device. This vacuum control meter shows you that the vacuum lifting unit is ready to operate and carry objects. As soon as the device is switched to "Suction" and thus the vacuum is in effect at the suction plates, the vacuum gauge shows the exact level of vacuum present. The scale is divided into a red zone (0% to 50 %) and a green zone (>50 % to 100%). As long as the indicator is in the red zone, no load may be attempted to be lifted or moved. Loads may only be lifted and transported when the indicator is in the green zone. A vacuum gauge on the main beam indicates the vacuum present in the accumulator (not available on standard units).

### Warning device:

In addition to the vacuum control meter, there is an electronic warning device installed, which provides an audible warning, and if necessary optically with a red warning light, when the pressure is too low. The vacuum lifting unit is then not ready for transport, as long as the siren is actuated and, if applicable, the red warning light is blinking.

### DANGER!



#### **Falling loads!**

A vacuum that is too low can allow the object being transported to break away, causing serious injuries.



- ✓ The operational readiness of the warning device must be checked **on a daily basis** right before use of the unit, and especially after extended inactive phases.
- ✓ No loads may be picked up and transported when the vacuum is low (indicator of the vacuum control meter is in the red zone, siren sounds, possibly red warning light blinks). **Loads already picked up must be put down immediately!**

How the warning device works:**Warning device with audible signal and if applicable RED/GREEN LIGHTS**

The warning device is located under the aluminium housing.

The siren is located at the top right part of the main frame. The main switch is installed on top.

The low pressure switch measures the vacuum in the vacuum accumulator.

The siren is actuated when the vacuum in the vacuum accumulator falls below 50 %. Moreover, the vacuum generator and the electronic low pressure switch, which measures the vacuum present in the device and regulates the pump control system, are located under the housing. There is also a battery charger (external), the batteries themselves, and the device's entire electronics.

In addition to both vacuum gauges, there are also red/green lights installed. They are used to monitor the vacuum in the vacuum accumulator. If the vacuum level in the accumulator is low (< 50 %) , the red light will blink, the green light will be switched on when the vacuum level is sufficient (> 50 %) for transport operation.

**Comment:** After switching on the device, the actuation of the siren is suppressed electronically.

The siren is only actuated and operational after the vacuum is greater than 50 % and the device is ready to operate!

**DANGER!****Electrical voltage!**

Do NOT open the housing when the device is energized. Can cause death, burns and property damage.

- ✓ Prior to switching on the device, visually inspect the electrical wires and condition of housing or cover!

**7.8 Checklist in case of malfunctions**

<b>Problems:</b>	<b>Cause:</b>	<b>Remedy:</b>
Vacuum level drops significantly.	Product to be transported is cellular or permeable to air.	Vacuum lifting unit is not suited for this load.
	Suction plates not applied properly.	Change suction plate position.
	Suction plate seal defective.	Replace seal.
	Vacuum control meter defective.	Replace vacuum gauge.
	Vacuum hose defective.	Replace hose.
Vacuum of 70% is not attained	Vacuum pump defective.	Replace pump.
Vacuum drop during transport.	Vacuum hose defective.	Replace hose.
	Vacuum pump defective.	Replace pump.
	Suction plate seal defective.	Replace seal.
Suction/Release no longer function.	Possibly manual sliding valve, electromagnetic valve or pulse valve defective.	Replace defective parts.
Load leans more to one side	Load not picked up at center of gravity.	Pick up load again.

## 8 Maintenance and repair

### 8.1 Instructions

Malfunctions that can be attributed to insufficient or improper maintenance of the device may result in expensive repairs and an extended downtime. That is why regular maintenance is absolutely necessary.

According to the accident prevention regulation **DGUV Regulation 100-500 (BGR 500)**, the vacuum lifting unit must undergo an annual inspection by an expert. The inspection date can be found on the inspection sticker that is attached to your vacuum lifting unit. Please inform us as an expert for the relevant UVV-prescribed inspection.

#### Spare parts:

- Only original AERO-LIFT replacement parts may be installed.
- It is recommended to keep diverse spare parts in storage.
- Spare parts may only be replaced/installed by authorized competent personnel.
- Work on the pneumatic system and vacuum equipment may only be carried out by a specialist.

### DANGER!



#### Electrical voltage!

Can cause death, burns and property damage.

- ✓ Prior to carrying out any servicing or cleaning of the vacuum lifting unit, especially the warning system, the main switch must be switched off and the unit disconnected from the power supply.
- ✓ Maintenance of the electrical system may only be carried out by a qualified electrician.
- ✓ Regular visual inspection of electrical lines for external damage.

## 8.2 Inspection and maintenance list

Area:	Part to be Inspected:	Frequency:	Maintenance instructions
1.	<b>Vacuum</b>		
	Vacuum pump		see Annex
	Vacuum filter	Weekly	Blow out filter with compressed air or replace depending on condition.
	if nec. Water separator	when water is found in the water separator!	As soon as water is found in the water in water separator, drain it off using the drain plug. Afterwards, replace and tighten the drain plug and let the vacuum pump run for approx. 10 minutes!
	Suction plates, seal	Daily	Replace if defective.
	Hose connections	Daily	Tighten hose clamps if applicable
2.	<b>Vacuum test</b>		
	Functional check	Daily	Compare the actuation of the red/green lights with the vacuum gauge if applicable, at the same time with the switchover to "red", the siren must also be actuated and/or the vacuum control meter must read < 50 %. Check maximum value fluctuations of vacuum gauge.
3.	<b>Vacuum valve</b>	Daily	Suction/release function
4.	<b>Entire device</b>	Daily	Checking for visible deficiencies and malfunctions.
5.	<b>Inspection sticker</b>	Annually	Check according to <b>DGUV Regulation 100-500 (BGR 500)</b> , request an AERO-LIFT expert

### 8.3 Replace the seal at the respective suction plate

**“Install the designated replacement seal in accordance with the device’s design”!**

#### **Steps to follow for suction plate with tension band**

1. Loosen the tension band on the suction plate using the screw and slide upwards.
2. Remove the old seal from the aluminum base plate.
3. Slip the new seal on to the base plate.
4. Install the tension band and tighten using the screw.
5. Always perform a leak detection test upon completion of such services!  
(According to section “Leak detection test”).

#### **Steps to follow for suction plate with fixed threaded connection to base plate**

1. Unscrew defective seal from the base plate.
2. Screw the new seal back onto the base plate. If an additional seal ring is needed, insert it precisely into the provided groove before screwing together!
3. Always perform a leak detection test upon completion of such services!  
(According to section “Leak detection test”).

#### **Steps to follow for suction plate with a C-rail bracket or specific groove**

1. Remove defective seal from the C rail.
2. Insert new seal into the C rail. Make sure that the seal cannot be damaged.
3. Moreover make sure that the inserted seal with the back rests completely on the bottom of the C rail - Make sure that you check!
4. Always perform a leak detection test upon completion of such services!  
(According to section “Leak detection test”).

#### **Steps to follow for suction plate with a teardrop seal (AL 230 T, AL 140 T)**

1. Remove defective seal from the base plate.
2. Clean base plate, if necessary.
3. Apply new teardrop seal to base plate.
4. Always perform a leak detection test upon completion of such services!  
(According to section “Leak detection test”).

#### **NOTE**

Upon completion of this service, **always** perform a leak detection test!  
(See section “Leak detection test”).

## 9 Spare parts list

<b>Electrical components</b>		
<b>Designation / Type:</b>	<b>Item number:</b>	<b>Comment:</b>
Vacuum switch	2020223	digital
LED red XB5AVB4	2049072	
LED green XB5AVB3	2049073	
Warning device/No. of wiring diagram	3049550	Appendix, AL24 LP1M
Charger	3042041	24 V – 1 A
Battery 12 V, 3.4 Ah	2042042	
Siren	2049041	24 Volt
<b>Vacuum components and other parts</b>		
<b>Designation / Type:</b>	<b>Item number:</b>	<b>Comment:</b>
Diaphragm vacuum pump VAL 0.7, 24 V	2010132	see Annex
Manual sliding valve 1/4" I/I with safety lock	2020929	Suction/Release
2-2-way valve	2042255	Upstream of pump
Vacuum filter 1/4"	2020093	
Vacuum gauge Ø 40 mm	2020845	
Non-return valve 1/4"	3031142	
Vacuum hose to pump	2020408	LW 8, transparent
Vacuum hose to manifold / suction plate	2020151	LW 10, transparent
Seal vulcanized on aluminium plate	2032177	
Suction plate compl. SPL360G NBRswstarr	3027543	
Vulcanised seal on aluminium plate	2032177	
Suction plate compl. SPL270R NBRswstarr	3027544	
Vulcanised seal on aluminium plate	2031211	
Suction plate compl. SPL245M	3027545	
Vulcanised seal on aluminium plate	3031260/2032073	
Suction plate compl. SPL300M	3027546	
Vulcanised seal on aluminium plate	3031350/2032073	

**We only recommend using original AERO-LIFT parts, the properties, quality and functional characteristics of which are warranted.**

## 10 Warranty

The manufacturer provides a warranty for the vacuum lifting unit in case of any defects that can be **verifiably** attributed to faulty workmanship. The warranty extends to the remediation or replacement of the defective part. Our terms and conditions of sale apply exclusively. **The defective original parts must be sent back to us freight-paid.**

The warranty is valid for **one year (not including wear parts)** with regard to normal one-shift operation. The warranty period decreases accordingly based on the deviation from the normal one-shift operation.

The warranty period commences with the delivery of the vacuum lifting unit.

Our warranty does not cover the costs of repairs and replacements which are the result of work performed without our express written authorization.



## 11 EU Declaration of Conformity

- according to** - EC Machinery Directive 2006/42/EC, Annex II A from May 17, 2006  
 - EC Low Voltage Directive 2014/35/EU from February 26, 2014  
 - EMC Directive 2014/30/EU from February 26, 2014

We hereby declare that the below-mentioned machine developed by us in terms of design and type, as well as the version marketed by us comply the underlying health and safety requirements of the EC Directive of 2006/42/EC. This declaration loses its validity if any alteration is made to the machine that has not been coordinated with us.

**Manufacturer/authorized representative: AERO-LIFT**  
**Vakuumtechnik GmbH**  
**Turmstraße 1**  
**D - 72351 Geislingen**

**Description of machine:**  
 Type of machine / system: **Vacuum Lifting Unit**  
 Type designation: **AERO CUBE /**  
 Machine number:  
 Built in:

**Applied harmonized standards, in particular:**

- EN ISO 12100: 2010 Safety of machinery
- EN 61000-6-2: 2006-03 Electromagnetic Compatibility- Immunity for industrial environments
- EN 61000-6-4: 2011-09 Electromagnetic Compatibility- Emission standard for industrial environments
- EN 842: 2009-01 Visual danger signals
- EN 1005 – 2: 2009-05 Manual handling of machinery and component parts
- EN 60 204 – 1: 2019-06 Electrical equipment of machines
- EN 13155 Cranes - Non fixed load lifting attachments

**Other applicable technical standards and specifications:**

- **DGVV Regulation 100-500 (BGR 500, chapter 2.8)** Load lifting attachments in hoisting operations

Authorized representative for technical documentation:  
 AERO-LIFT Vakuumtechnik GmbH, Turmstr. 1, 72351 Geislingen

**Location/Date:**  
 Geislingen-Binsdorf,

**Information relating to signatory:**



.....  
 Tobias Pauli  
 Managing Director

- Original Declaration of Conformity
- Translation Declaration of Conformity

### 12 Annex

- Sheet metal overhang

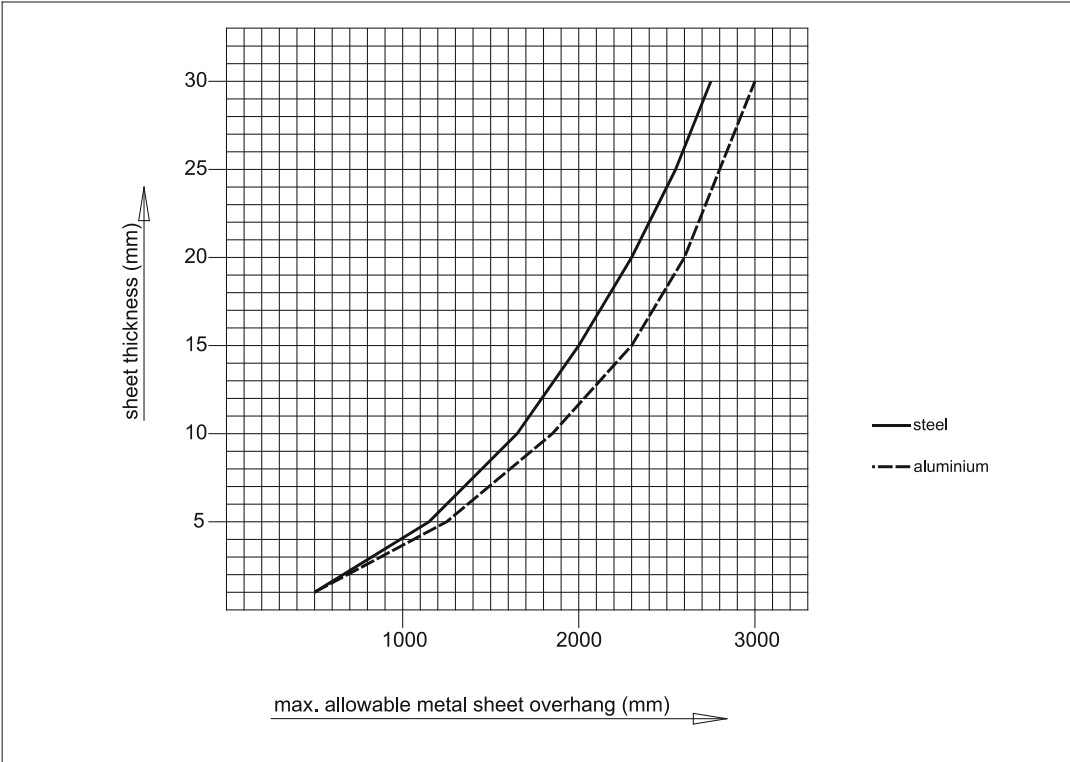
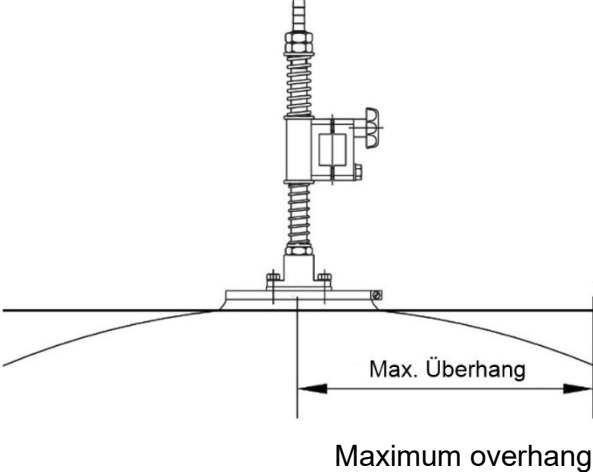

- **Glass overhang**

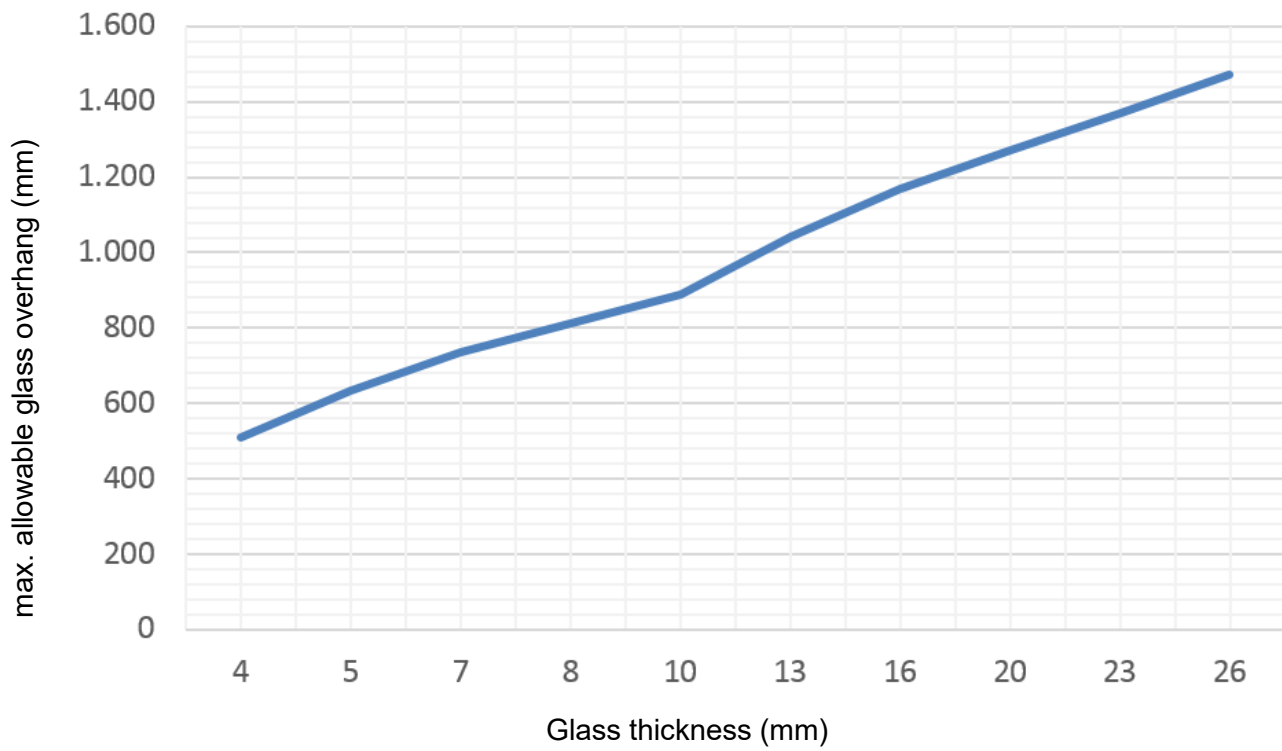
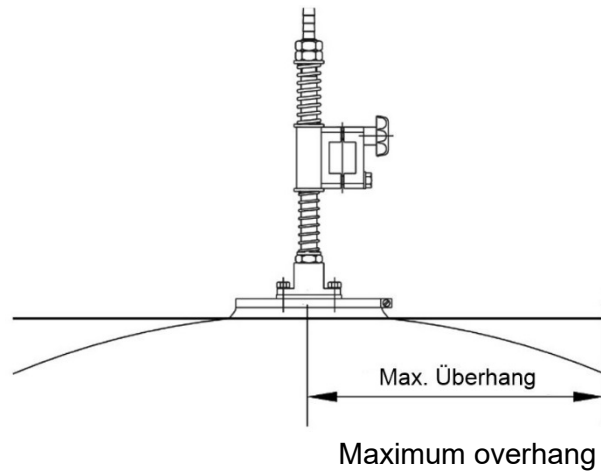

- **Electrical wiring diagram**

			AERO-LIFT Vakuumtechnik GmbH Turmstrasse 1, 72351 Geislingen Tel: + 49 ( 0 ) 7428-94514-0 Fax: + 49 ( 0 ) 7428-94514-38		
<b>Schaltplan / Connecting diagram / schéma de circuits:                  Warneinrichtung / Warning appliance / signal d'avertissement:                  AERO-CUBE</b>					
Artikelnummer / article No. / numéro d'article: <b>3049550</b>					
				Erstellungsdatum: 17.11.2022 Änderungsdatum: 08.12.2022	
				17.06.2022 Tech. Officer	
				AERO-CUBE Tech. vers.	
				AERO-LIFT Vakuumtechnik GmbH	
				Techn. / Front page	
				144/030	
				1/1	
8EDVZ					

**Plant information**  
**Anlageninformationen**

<b>Usage:</b> <b>Verwendung:</b>	<b>Color</b> <b>Drahtfarbe:</b>	<b>Color code according</b> <b>IEC 60752</b>	<b>Wire cross section</b> <b>Querschnitt</b>
Supply voltage / Betriebsspannung: 400V 50/60Hz	Black / Schwarz	BK	1,5/0,75mm <sup>2</sup>
Protective earth / Schutzleiter (PE):	Green-yellow / Grün-gelb	GNYE	Supply line cross-section / Zuleitungsquerschnitt
Control voltage / Steuerspannung (N): 230V 50/60Hz	Light blue / Hellblau	BU	0,75mm <sup>2</sup>
Control voltage / Steuerspannung (L): 230V 50/60Hz	Red / Rot	RD	0,75mm <sup>2</sup>
Control voltage / Steuerspannung (L+): <=24VDC	Dark blue / Dunkelblau	(D)BU	0,75mm <sup>2</sup>
Control voltage / Steuerspannung (L-): <=24VDC	Dark blue White / Dunkelblau-Weiss	(D)BUWH	0,75mm <sup>2</sup>
External voltage / Fremdspannung Pre main switch / vor dem Hauptschalter UPS circuit / USV Stromkreis	Orange / Orange	OG	1,5mm <sup>2</sup>
<b>Technical documents / Techn. Unterlagen:</b> Circuit diagram / Stromlaufplan BOM / Stückliste		<b>Wiring / Verdrahtung:</b> <=0,75mm <sup>2</sup> H05V-K > 0,75mm <sup>2</sup> H07V-K	The indicated cross-section is to be applied, if no further details are given in the plan. Der angegebene Querschnitt ist anzuwenden, sofern im Plan keine weiteren Angaben gegeben sind.
<b>Regulations / Vorschriften:</b> In accordance with DIN EN 60204 / VDE 0113 In Anlehnung an EN 60204 / VDE 0113	These plans are drawn with the CAE system E-Plan. Changes should only be made with the CAE system using the original parameters. Diese Pläne sind mit dem CAE-System E-Plan gezeichnet. Änderungen sollten nur mit dem CAE-System unter Verwendung der Original Parameter durchgeführt werden.		

BEAAG		L16.0102		AERO-LIFT Vakuumtechnik		Anlageninformationen / Plant information		REFS10	
DATE	REV.	DATE	REV.	AERO-CUBE		DATE		DATE	REV.
				REFS10					
DATE	REV.	DATE	REV.	REFS10					

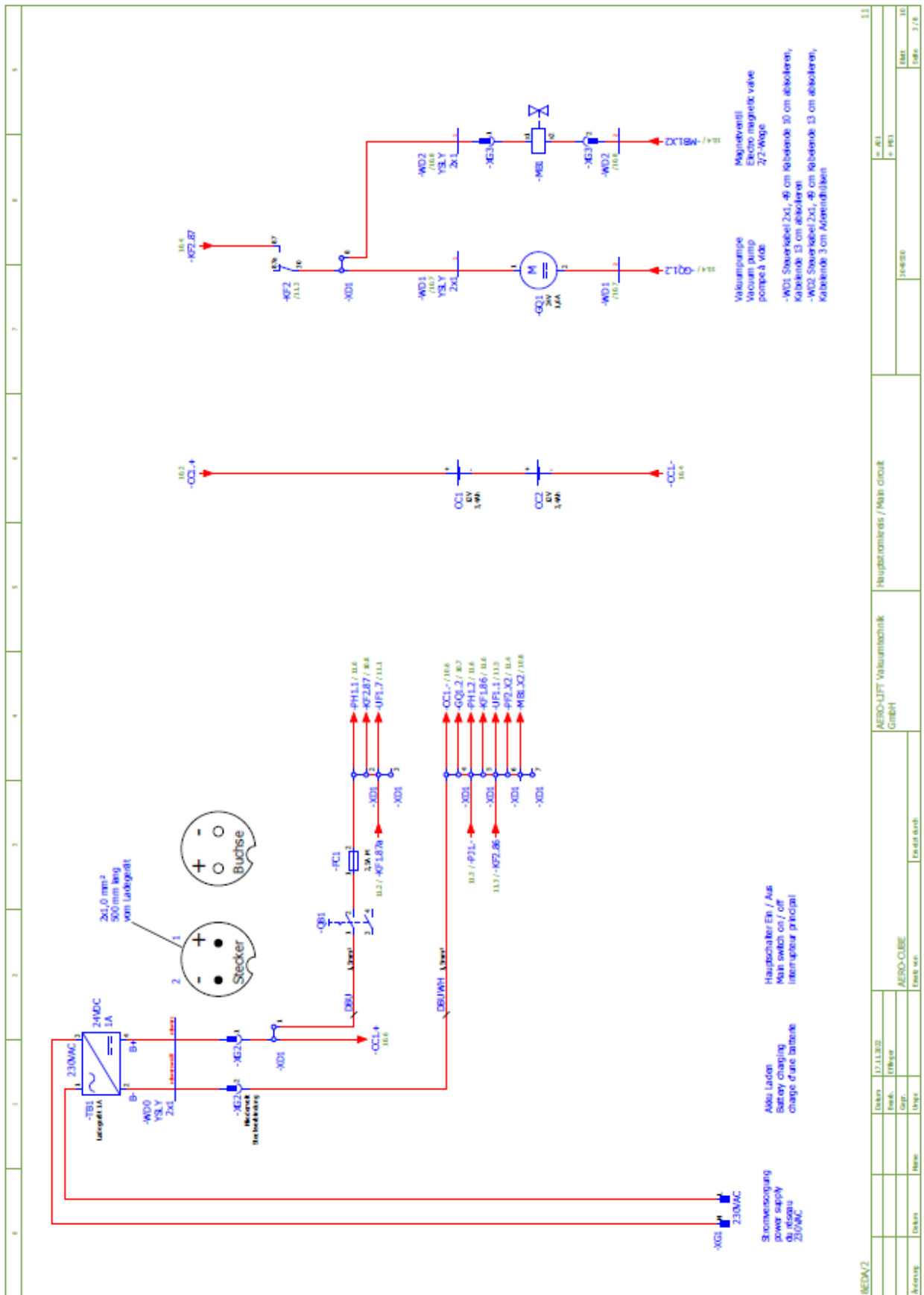

BEZA/2	17.11.2023	AERO-LIFT Vakuumtechnik GmbH	Hauptstromkreis / Main circuit	11
Druck	Druck	AERO-CUBE	Hersteller	10
Druck	Druck	Druck	Druck	10

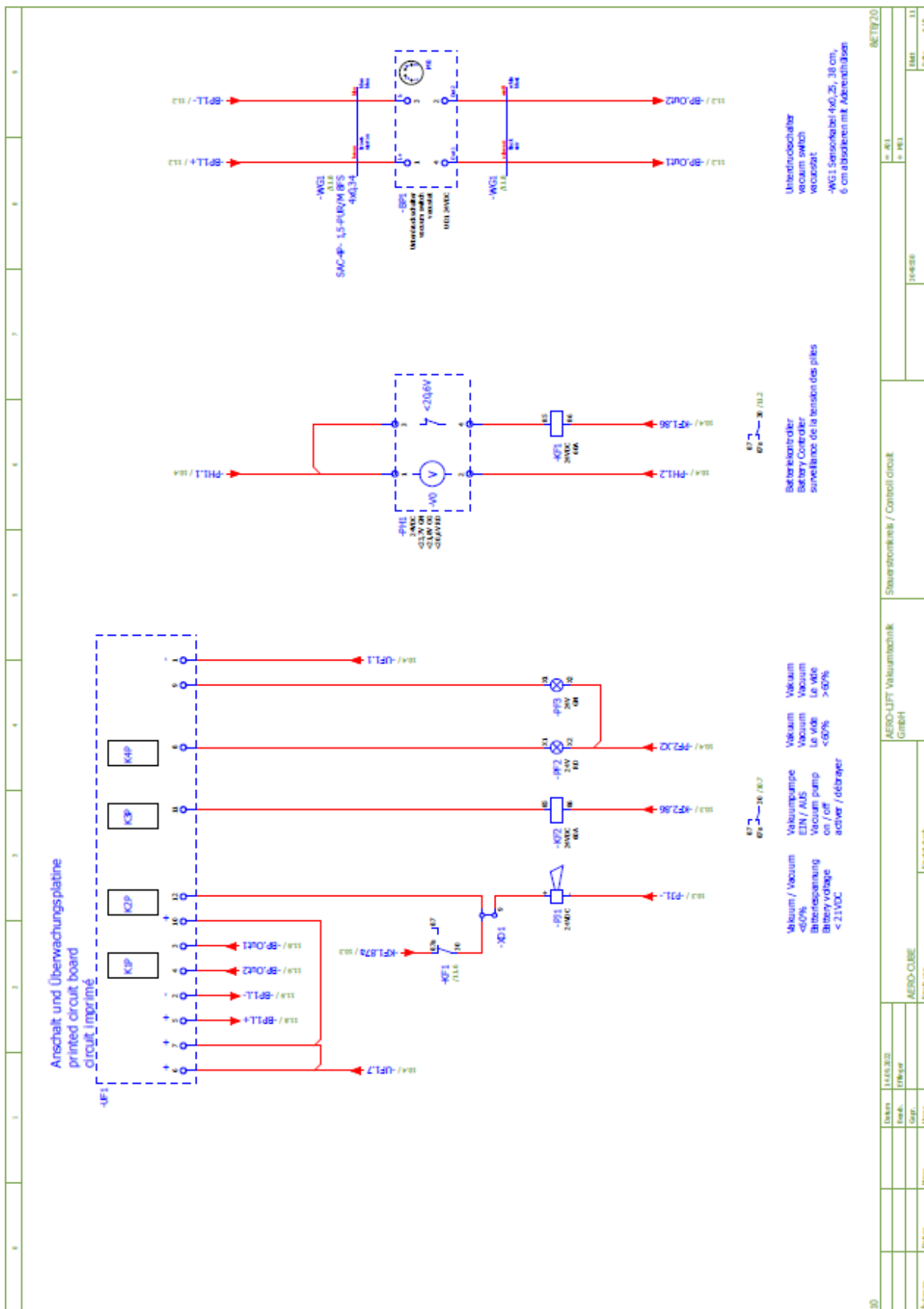

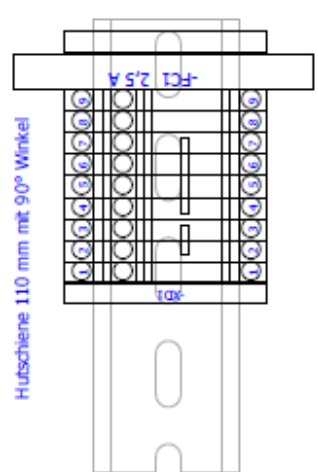
 <p>Hutschiene 110 mm mit 90° Winkel</p>																												21																						
REFS/11	Date:	11.05.2023	Name:	THW/ST	Proj.:	AERO-CUBE	Rev.:	001	Date:	01.05.2023	Page:	1/1	AERO-LIFT Vakuumtechnik GmbH	Montageplatte / Mounting plate	Zeichn. Nr.:	10000000	Blatt:	1/1	Blatt:	1/1	Blatt:	1/1																												





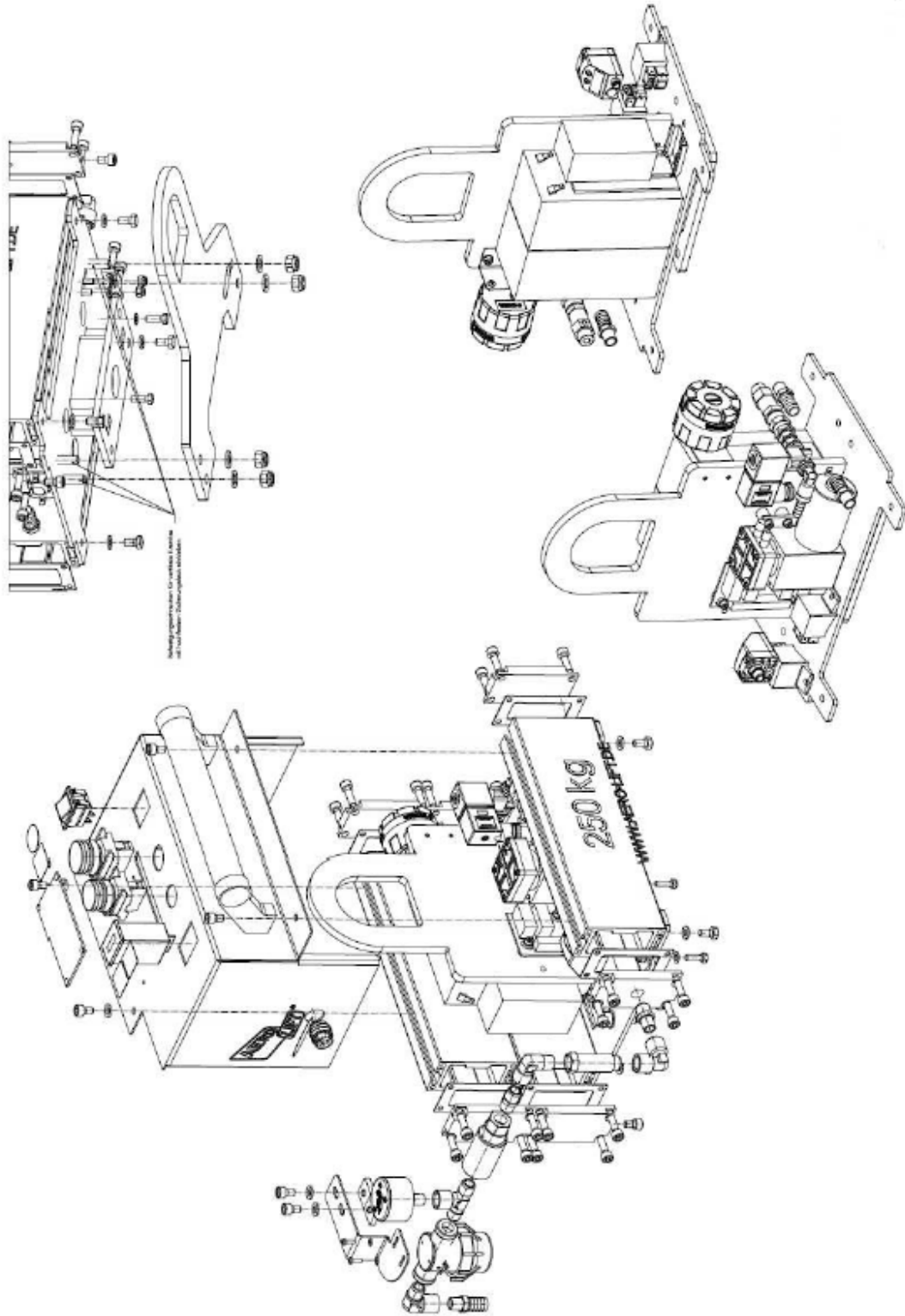

Zf	DIN EN ISO 9001 DIN EN ISO 14001	AERO-CUBE Pack set	Ex-ent date	AERO-LIFT Vakuumtechnik GmbH	Exploded drawing / explosion drawing	1000000	1000000	1000000	1000000
						1000000	1000000	1000000	1000000



- Vacuum pump datasheet



.....VAL 0,7 - 24V

**Flow Curves**

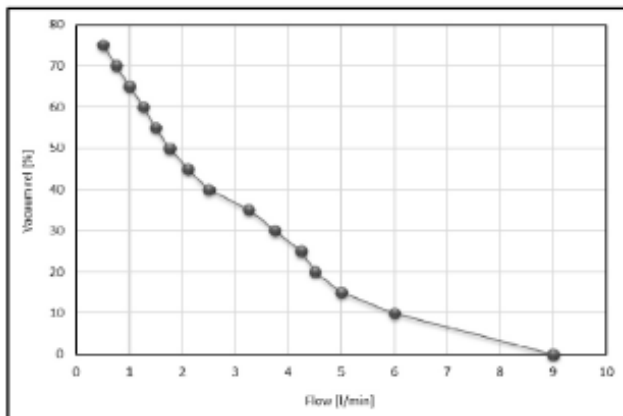

**Technische Daten**

max. Saugleistung: 0,7 m³/h  
 max. Vakuum: 75 %  
 Pumpentyp: Membranpumpe  
 Spannung: 24V DC  
 Stromaufnahme: 1,4 A  
 Motorleistung: 32 W  
 Gewicht: 0,55 kg  
 Geräuschpegel: < 70 dB (A)  
 Bestell-Nr.: 2010132

**Technical specifications**

max. flow: 0,7 m³/h  
 max. vacuum: 75 %  
 theory: diaphragm pump  
 nominal voltage: 24V DC  
 current consumption: 1,4 A  
 motor power: 32 W  
 weight: 0,55 kg  
 sound level: < 70 dB (A)  
 order nr.: 2010132

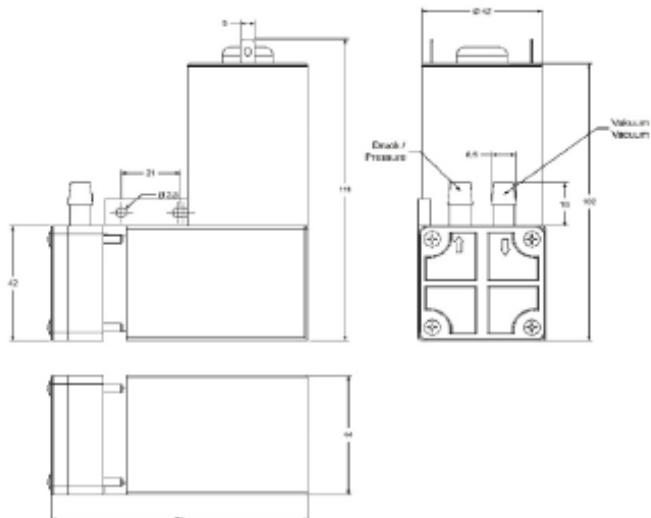

AERO-LIFT Vakuumtechnik GmbH  
 72351 Geislingen  
 Turmstraße 1  
 72351 Geislingen Binsdorf  
 Deutschland

Fon +49 7428-94 514-0  
 Fax +49 7428-94 514-38  
 www.aero-lift.de  
 Mail: info@aero-lift.de

creation of: Mr. Schmitz  
 date: 04.01.2018  
 place: Geislingen - Binsdorf

- **Additional hazards occurring during operation of vacuum lifting unit:**

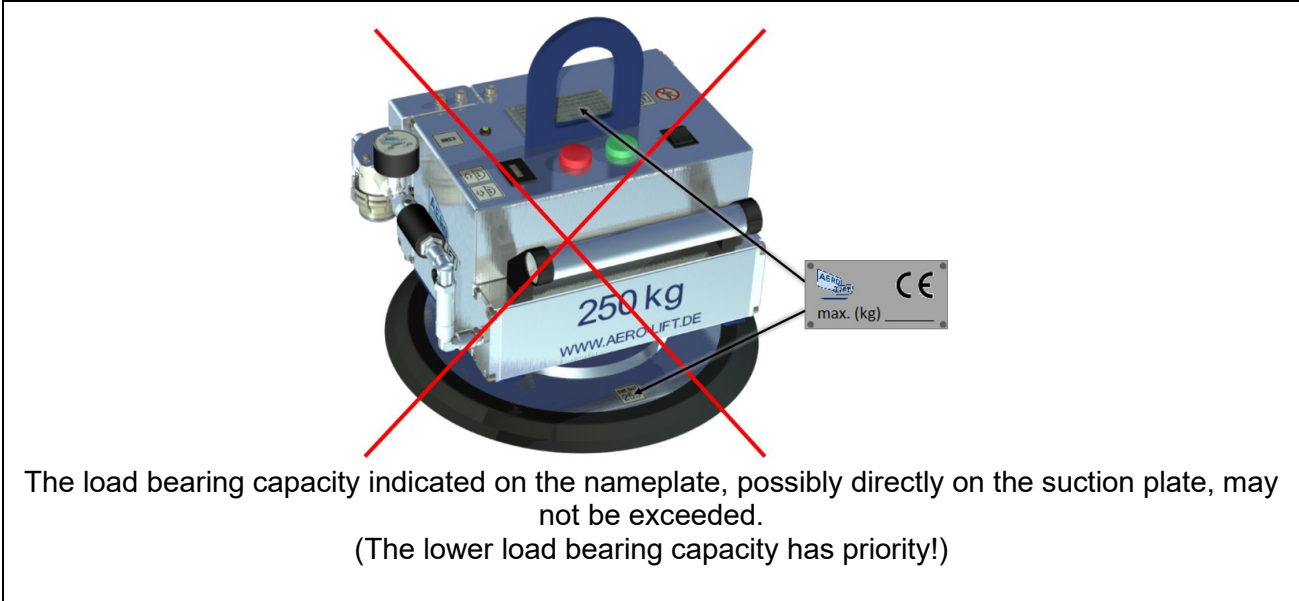

- Overview drawing of the different (optional) AERO CUBE versions

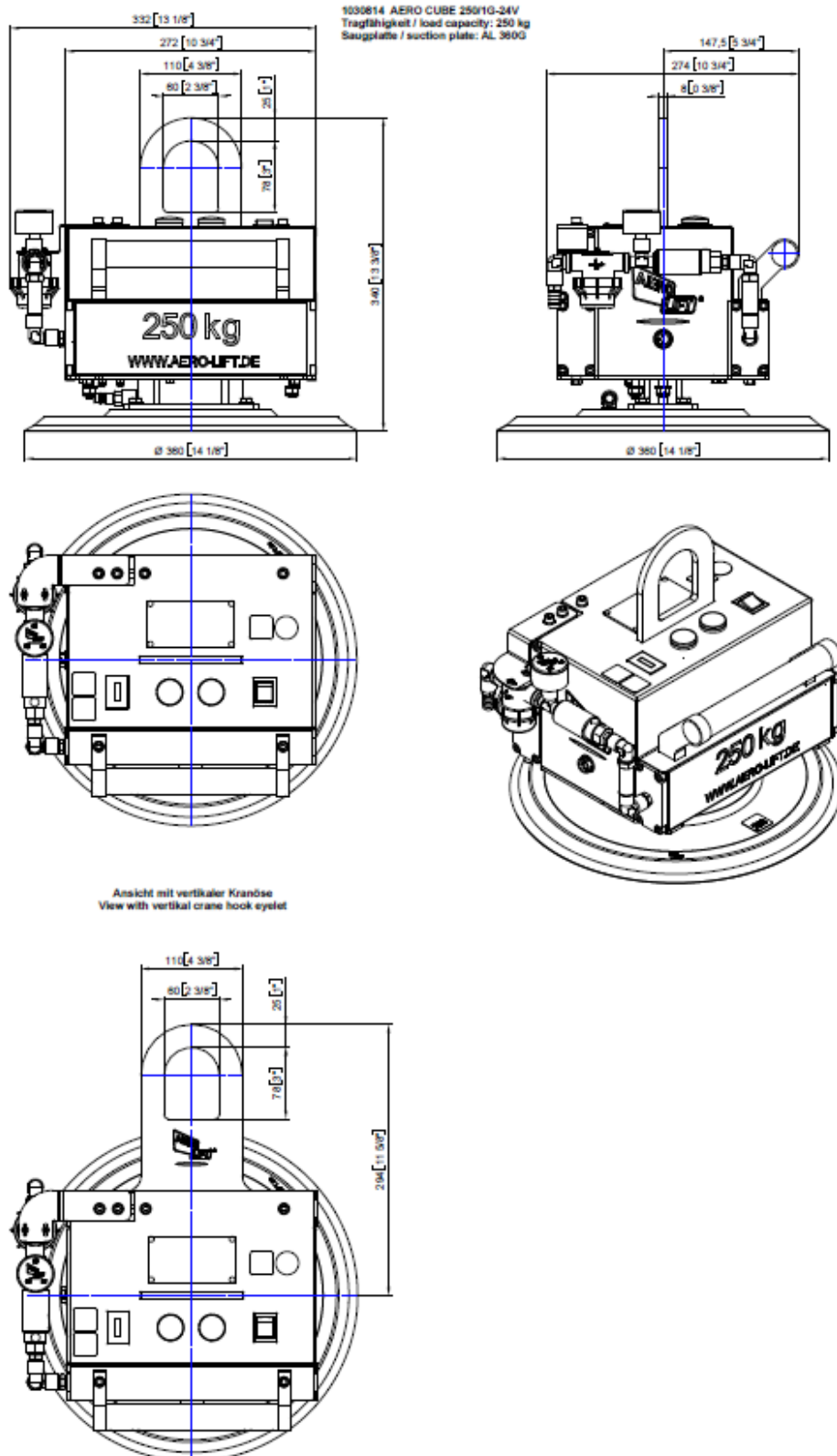

1030815 AERO CUBE 135/1R-24V  
 Tragfähigkeit / load capacity: 135 kg  
 Saugplatte / suction plate: AL 270R

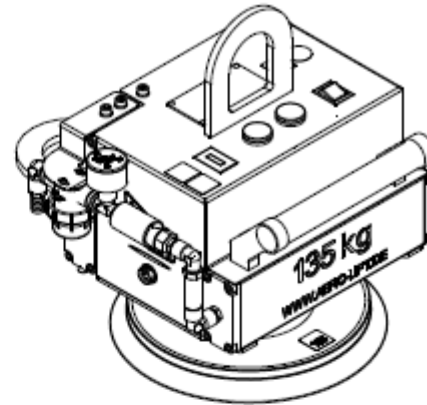
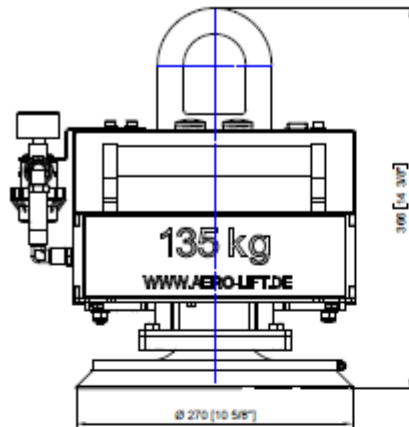

1030816 AERO CUBE 90/1M-24V  
 Tragfähigkeit / load capacity: 90 kg  
 Saugplatte / suction plate: AL 245M

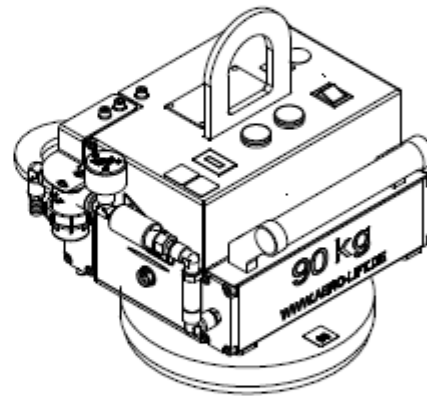
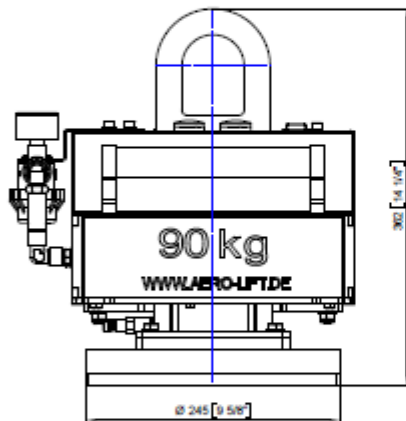

1030818 AERO CUBE 145/1M-24V  
 Tragfähigkeit / load capacity: 145 kg  
 Saugplatte / suction plate: AL 300M

