

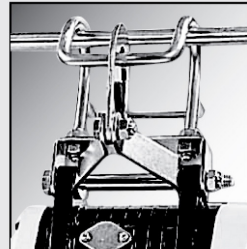

Model: CWS-80  
CWS-160  
CWS-230  
CWS-300



○ INSTRUCTION  
MANUAL

**Baby Winch**





## Compact Winch

Thank you for purchasing a **COME-UP** Winch. This manual covers operation and maintenance of the winch. All information in this publication is based on the latest production information available at the time of printing.

### General Safety Precautions

A **COME-UP** Winch is designed to give safe and dependable service if operated according to the instructions. Read and understand this manual before installation and operation of the winch.

Follow these general safety precautions:

- Confirm that the winch complies with the using conditions.
- Keep the winch secure strongly and the rope is not wound to be deviated to the drum.
- Don't use unsuitable pulleys or accessories concerned.
- Don't use unsuitable rope in construction , strength or having any defects.
- Pay attention to the grounding , it provides a path of least resistance for electric current to reduce the risk of shock.
- Check the winch for smooth operation without load before loading operation.
- Make sure the wire rope to be wound evenly in the first layer on the drum, rewind it if a mixed windings in existence.



#### **WARNING**

- 1.The winch is not to be used to life, support or otherwise transport personnel.
- 2.A minimum of five(5) wraps of rope around the drum is necessary to support the load rated.
- 3.Come-Up takes no responsibility for the subsequent performance of mechanical components if oil possessing properties other than what Come-Up recommends is used

## I.SPECIFICATION

MODEL		CWS-80	CWS-160	CWS-230	CWS-300
Lifting capacity kg		80	160	230	300
Wire rope top layer					
Lifting speed m/min	first layer	30	22	14	13
	top layer	18	15	9	9
Motor kwxA	110V	0.8 × 8	1.2 × 12	1.3 × 13	-
	220V~240V	0.8 × 4	1.2 × 6	1.3 × 6.5	1.5 × 7.5
Lifting height m		23	30	24	24
Wire rope φ mm x M		4 x 24	4.8 x 31	5 x 25	4.8 x 25
STANDARD ACCESSORIES	Power cord	220V~240V	1.5 mm <sup>2</sup> x 3c x 5M		
		110V	2.0 mm <sup>2</sup> x 3c x 5M		
	Switch cord		1.25 mm <sup>2</sup> x 6c x 10M		
	Swivel hook		CHW-0032 x 1	CHW-0033 x 1	

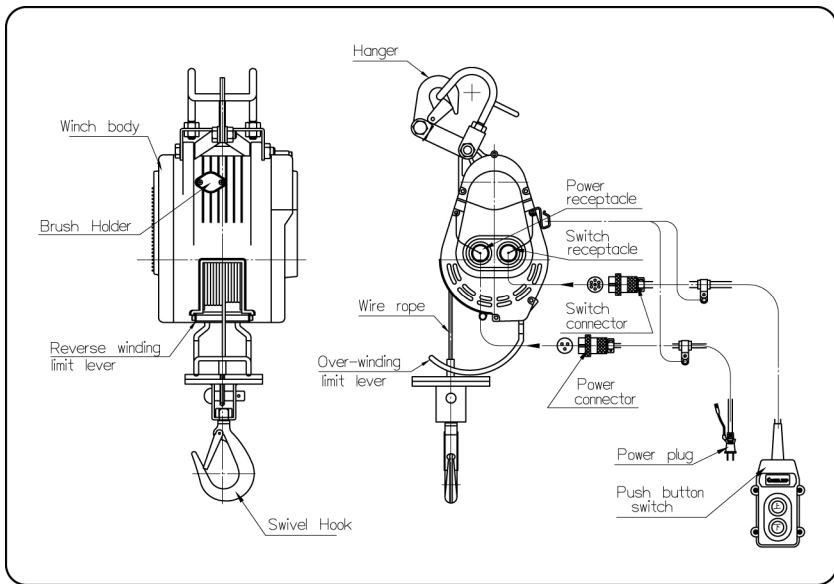







### ⚠ WARNING



1. The owner and/or the operator shall have an understanding of these operating instructions and the following warning before operating the electrical winch. Failure to follow these warnings may result in loss of load, damage to the winch, property damage, personal, or fatal injury.
2. Warning information shall be emphasized and understood. If the user is not fluent in English, Instructions and warnings shall be read to and discussed with the user in the user's native language by the owner to make sure that the user comprehends the contents.
3. The owner shall retain this manual for further reference to important warnings, installation, operating and maintenance instructions.

## II. INSTALLMENT PRECAUTION

### 2.1 ENVIRONMENT PRECAUTION

 <b>WARNING</b>	
	<ul style="list-style-type: none"> <li>•The following environmental conditions may result in the possible causes of winch trouble.</li> </ul>
<ul style="list-style-type: none"> <li>•Low temperature below -10°C, high temperature above 40°C or humidity above 90% conditions.</li> <li>•In heavy acid or salty conditions</li> </ul> <p>※Cause malfunction of spare part.</p>	 <ul style="list-style-type: none"> <li>•In a organic chemistry or explosive power conditions.</li> </ul> <p>※ Cause explosion.</p> 
<ul style="list-style-type: none"> <li>•In the rain or snow</li> </ul> <p>※Cause rust or short circuit.</p>	 <ul style="list-style-type: none"> <li>•In a heavy general powder conditions.</li> </ul> <p>※ Cause malfunction of performances.</p> 

### 2.2 CONTINUOUS RATING

 <b>WARNING</b>	
	<ul style="list-style-type: none"> <li>•Never hoist over the rated percentage duty cycle.</li> </ul>

The life of the winch is depending on the conditions of the load and working frequency.

In the long time operation, make sure to use the machine within its continuous ratings.

Continuous ratings means the working duty cycle (%ED) is subject to the rated voltage, rated frequency and a 63% of rated load.

$$\text{Percentage duty cycle (\%ED)} = \frac{T_b}{T_b + T_s} \times 100 (\%)$$

T<sub>b</sub>: total sum of overall loadings operating hours.

T<sub>s</sub>: total sum of stopping hours.

T<sub>b</sub>+T<sub>s</sub>=approximately 1 to 10 min

## 2.3 MOUNTING

The winch designed to be hanged or mounted on a firm or stable bar or a bracket CRH-0710 (as an option).

When hanging, do not allow the body or load to be caught by any construction of frame, or other obstruction.

Be sure to lock the hanger for extra safety.

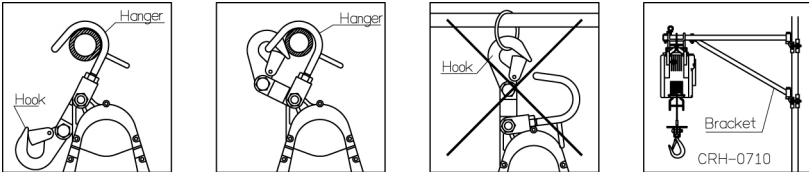

## 2.4 PLUG INSERTION

### 2.4.1 Power core insertion

Insert the power plug into the power receptacle of the winch, and tighten it by turning the locking ring, clockwise.

Be sure to lock the cord by a holder. Do not allow the cords to be caught by wire rope and drum.

The length of power cord is subject to the distance of 20 meter, for any other case, please use a power cord by 3.5 mm<sup>2</sup> to prevent a considerable voltage drop to be happened.

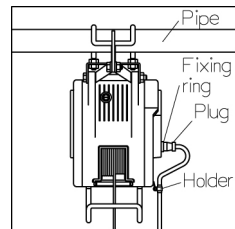

### The selection of power cord section

Voltage	Section	Maximum Length
110V	2.0 mm <sup>2</sup>	20 m
220V~240V	1.5 mm <sup>2</sup>	
110V	3.5 mm <sup>2</sup>	30m
220V~240V	2.0 mm <sup>2</sup>	

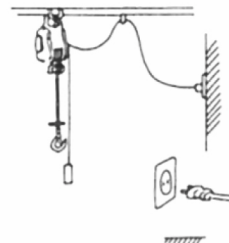

### 2.4.2 Grounding

To prevent the risk of electric shock, the power plug must be plugged into a matching outlet and grounded in good condition.

### 2.4.3 Switch cord connection

- 1) Insert the switch plug into the switch receptacle of the winch and tighten it by turning the locking ring clockwise. Be sure to hook the cord by a holder.
- 2) To extend the length of the switch cord, please adopt a switch extension cord EXC-0010 as an option.

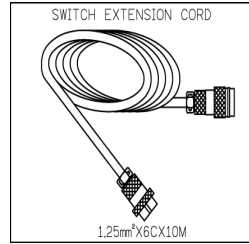

## III. WORKING METHODS

### 3.1 PREPARATION BEFORE WORKING

- Be sure to carefully check all safety and environmental conditions.
- A minimum of five (5) wraps of wire rope wound around the drum is necessary.  
A wire rope should be discarded and not be used again if rope shows sign of excessive wear, too many broken wires, corrosion or other defects.
- Make sure to connect the main power source and grounding.
- It's not safe to lift loads exceeding the rated load.
- Connect power source at rated voltage.  
(It will cause maladjusted working if input voltage falls out of rated voltage by +/- 10%)

### 3.2 UP AND DOWN SWITCHING

- To lift a load, press ↑ button and drum will rotate as shown below operation.  
To lower a load, press ↓ button and drum will rotate as shown below.

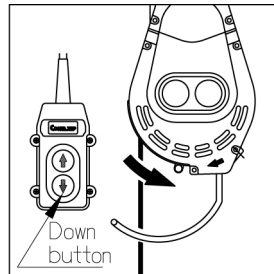
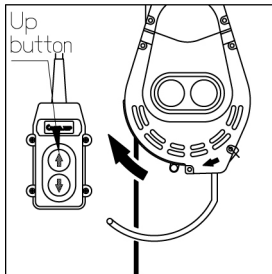

When the button is released, the drum will stop moving.

## IV. HANDLING PRECAUTION

### 4.1 ENVIRONMENT PRECAUTION



## WARNING



● Pay best attention to the following instruction. Obvious mistakes in operation may result in personal injury or equipment damage.

- Never try to lift a load more than the rated cap.



- Never hitch a ride on the hook, sling or load being moving.



- ※ Winches are not to be used for lifting or lowering people.

- Don't work, walk or stand under an operating winch..



- Always remain in control. Never neglect the winch while actually hosting a load.



- While working, never stand Under a lifting load or Within the conveying area.



- Never gravitate a load freely.



- Always look up when working around winch, there is potential danger overhead.

- ※ Be sure to lift a load vertically. Slack may allow wires to be caught in the drum.

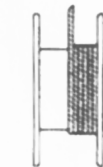

- Prior to starting of use, carry out the daily checking without fail, and after confirming the safety of function.



- If having a counter rotation incurred, make sure to correct its rotation direction.

- Prior to lifting. Make sure to have a precise performance of brake. If any malfunction of brake happened, stop the operation immediately.

- When load suspended in air, it will not allow to be welded. Never weld a load while actually lifting a load.



- Wire rope with one or more of the following defects shall be removed or replaced immediately.

- 1)kink.
- 2)distortion.
- 3)corrosion.
- 4)showing sings of excessive wear or of having broken wires not less than 10 pcs.

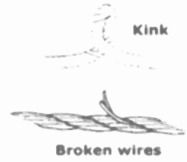

- Stop the operation if there is any queer noise or vibration in the gear box to be happened.
- Do not connect the wire rope with the grounding of welding machine.
- While welding, do not have any contact with the welding objects because of having spark.

- Do not pull the switch cord to move a load.



- Never plugging (instant reverse-wind) and inching.



- Do not over continuous ratings.

- In order to prevent the layer down due to over loosening of rope, irregular winding, etc., operate according to the suitable operating method.

- Use a winch by fixing so securely that the rope around the drum is uneven.

- Be sure to fix a rope in the center of swivel hook.

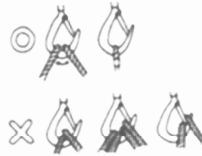

- Be sure to stop operation immediately when the wire rope become fully slackened.

- Avoid catching the hook or lifting a load on a fixed obstruction.

- Always leave the push button switch positioned immediately after use.



- Make sure that the load being lifting are well balanced and secured before starting.

- Avoid water splashes on the push button switch.

- Never wrap the load with the wire rope.





## V. MAINTENANCE AND REPLACEMENT

### 5.1 WIRE ROPE REPLACEMENT

#### 5.1.1 Swivel hook

- Put a new wire rope through the hole of the round plate of swivel hook.
- Insert a sleeve pin through the thimble of wire rope.
- Insert a pin through the sleeve pin and bent it by a pliers.

#### 5.1.2 Drum

- Let a new wire rope w/clamp through the limit lever and insert it into the hole of the drum.
- Put a P.T. screw into the hole of the drum and tighten it by a hexagon wrench.
- Press the ↑ button to rotate the drum in the lifting direction.
- A uneven winding of wire rope may cause the load to be swing, thus damaging the rope and reducing its life.

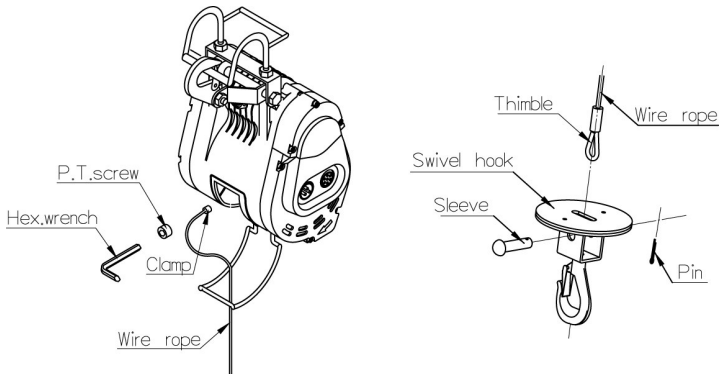

### 5.2 OIL LUBRICATION

Winch are prelubricated at the factory and do not require initial lubrication. Relubrication interval depends upon service. Recommended oil replenishment quantity & intervals are as follows.

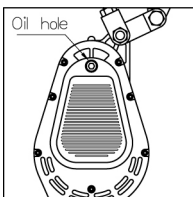

Grease Grade	Quantity				Intervals
	CWS-80	CWS-160	CWS-230	CWS-300	
NIGI NO.0					
Caltex Multifak EP	100 cc	250 cc	250 cc	250 cc	1 Year
Cosmogear SP460					

### 5.3 CARBON BRUSH REPLACEMENT



### WARNING



● Clean the accumulated powder of carbon brush periodically to ascertain the insulation resistance up to  $1M\Omega$ .

- It is essential to check the carbon brush periodically. If its length is left less than 7.5 mm resulting from wearing, it is absolute necessary to replace carbon brush immediately.
- While replacing, smoothly insert carbon brush into carbon holder in the first place, then put brush cap into the hole.
- Before tightening the carbon brush holder, make sure to position O-ring.
- A set of carbon brush consists 2 piece of carbon brush. Ascertain to replace 2 pcs of carbon brush on opposite sides of winch body at the same time.

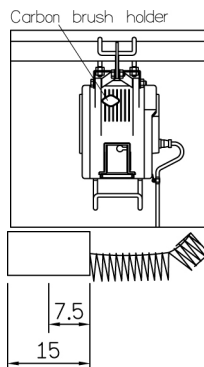

### 5.4 BRAKING

- Braking device are composed of a mechanic brake and a electronic generated brake. The brake distance from the time of braking until stopping completely should be within 1.5% of rope length to the wound in during 1 minute.
- Owing to the rope speed on no load is faster than that on rated load, the brake distance on no load will be longer, but still within 1.5% of rope length.
- The rope speed on no load is 1.5-1.8 times of rated speed on rated load.

### 5.5 OVER-WINDING LIFT PREVENTION DEVICE

- A special mechanism prevents a over-winding when lifting.
- When the swivel hook touches the limit lever. Lifting is automatically stopped.
  - However, if the limit lever is set too close to the winch body, it will cause serious damage to the limit lever and the winch body.
  - A suggested distance (5) between the limit lever

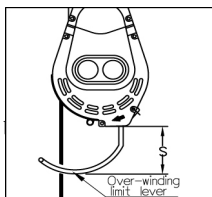

and winch

MODEL	CWS-80	CWS-160	CWS-230	CWS-300
DISTANCE	80-100 mm	70-90 mm	70-90 mm	70-90 mm

### 5.6 REVERSE-WINDING PREVENTION DEVICE

- A special mechanism prevents a over reverse-winding when lowering.
- When lowering, a wire rope is fully extended, the wire rope will be shifted its position from O to X.
- When a wire rope touches the limit lever of over-winding prevention device. Lowing will be automatically stopped.
- When the wire rope is shifted to the position of X, pull it and press the  $\uparrow$  button to return its position to O.

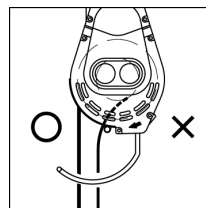

## VI. CHECKING AND TROUBLE SHOOTING

### 6.1 CHECKING REFERENCE.

CHECKING ITEMS			CHECKING METHODS	CLASSIFICATION OF CHECKS			
				DAILY	PERIODICAL		
					3 MONTH/ 20 HOURS	1 YEAR	3 YEAR
1	●BRAKE	Performance Wearing of lining, and pressed plate Brake or escaping of spring	Visual Decomposition check Decomposition check	▲			▲ ▲
2	●CARBON BRUSH	Wearing	Decomposition check		▲		
3	●MOTOR	Condition of insulation Staining, damage Carbon powder accumulation	Measuring.50MΩmin Visual Decomposition check	▲	▲	▲	
4	●CONTROL ASS'Y	Working Outer damage of switch cords Attaching condition of earth line Condition of insulation	Manual Visual Visual Measuring.50MΩmin	▲ ▲ ▲	▲		
5	●SAFETY DEVICE	Over-prevention function Reverse winding prevention function Distortion of over winding lever Wrong rotary direction-winding	Visual Visual Visual Visual	▲ ▲ ▲ ▲			
6	●WIRE ROPE	Kink phenomena Broken wires Decreasing of diameter more than 10% Deforming or corrosion	Visual Visual Visual Visual	▲ ▲ ▲ ▲			
7	●SWIVEL HOOK & HANGER	Distortion Damage Loosening	Visual Visual Visual	▲ ▲ ▲			
8	●DRUM	Rupture of flange Wearing	Visual Visual	▲	▲ ▲		
9	●GEAR CASE	Damage, waring Condition of oil feeding Lubrication for couplings	Visual Measuring Measuring	▲		▲ ▲	
10	●FASTENINGS	Loosening	Manual	▲		▲	
11	●MARKING	Label and the like	Manual				

- Remark :
- 1.The specified person performs the checking of winch.
  2. Divide the checking into daily checking and periodic checking.
  3. The checking items and checking method in daily and periodic checking are to be carried out and different according to the using frequency.

## 6-2. TROUBLE SHOOTINGS

Checking the winch for smooth operation by pressing up and down button of push button switch.

When winch fails to start after several attempts, or if any defective operation to be happened, check followings.

OBSERVED ANOMALY	POSSIBLE CAUSE	SOLUTION
No reaction after pressing the buttons of switch	No power	Check power source
	Disconnection of plug, power cord or switch cord	Replace or repair
	Burnt or communicated motor resulting from over load.	Replace
	Burnt diode ass'y.	Replace
		Clean motor
	Considerable voltage drop.	Adjust to rated voltage
Brake distance too long	Wearing of lining, pressed plate and pawl	Replace
	Disconnection of electronic generated feed-back braking	Repair nut and cord
	Too high voltage	Replace D type resistor
No over-winding prevention while swivel hook touches limit lever	Disconnection of electronic generated feed-back braking	Repair of nut and cord Replace D type resistor
	Malfunction of limit switch	Replace
Lifting speed too slow	Overload	Reduce load
	Considerable voltage drop	Adjust to rated voltage
		Check the section of power cord
Electricity leakage or shock	Burnt motor resulting from overload	Replace motor
	Wearing of carbon brush	Replace carbon brush and Clean carbon powder left in the motor
	Water invaded in motor or push button switch	Dry it Replace motor if too heavy water invaded
Abnormal sound in gear box	Insufficient oil resulting from oil leakage	Replace oil seal Fill with sufficient oil
	Distortion of gear box	Repair

## VII. WIRING DIAGRAM

### 7.1. FOR 100V~120V

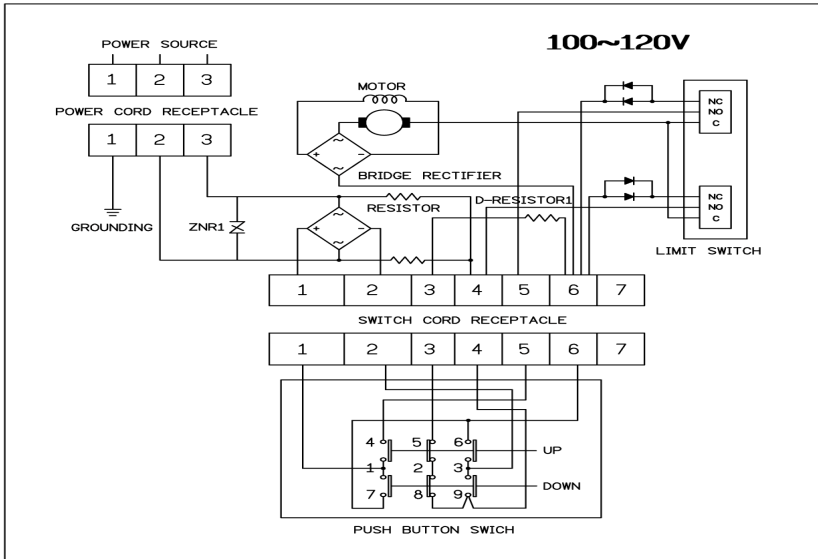

### 7.2. FOR 200~240V

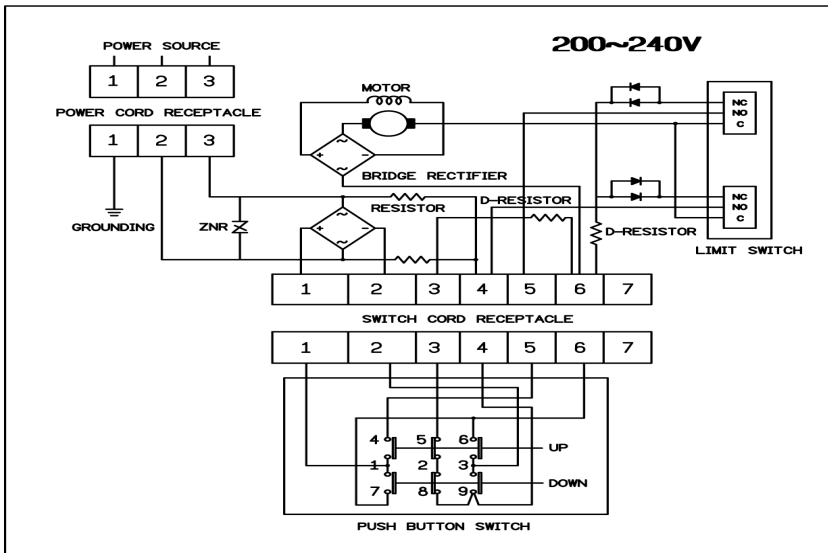

## VIII. Replacement Parts List

### ► CWS-80

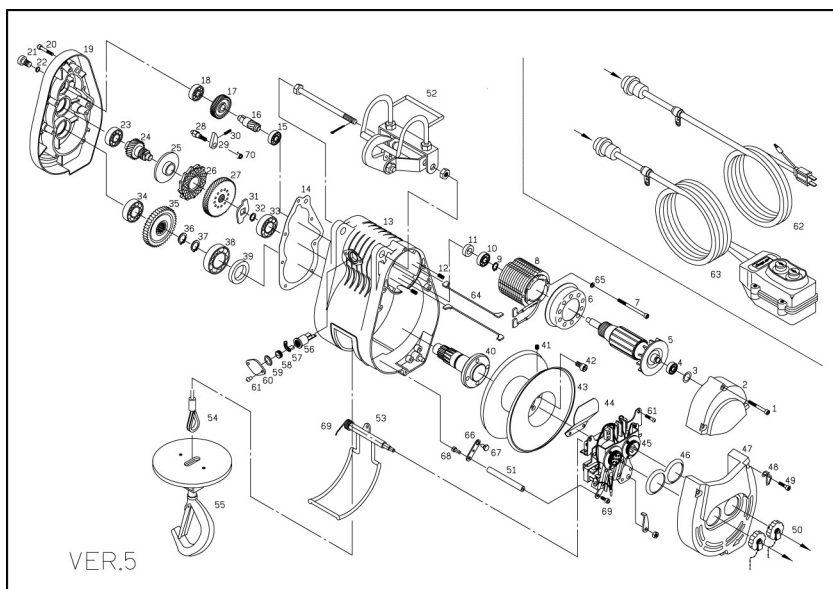

No.	Description	No.	Description	No.	Description
1	Hex screw	3	25 Brake disc	1	49 Hex bolt
2	Motor rear cover	1	26 Ratchet	1	50 Cap
3	Washer	1	27 2nd gear	1	51 Reverse winding shaft
4	Bearing	2	28 Set bolt	1	52 Suspension hook ass'y
5	Armature	1	29 Pawl	1	53 Limit lever (up)
6	Fan cover	1	30 Pressed spring fixture	1	54 Wire rope ass'y
7	Hex bolt	2	31 Retaining ring	1	55 Swivel hook
8	Field coil	1	32 Bearing	1	56 Carbon holder
9	Retaining ring	1	33 Bearing	1	57 Carbon brush
10	Bearing	1	34 Bearing	1	58 Brush cap
11	Oil ring	1	35 3rd shaft	1	59 O-ring
12	Knob pin	2	36 Retaining ring	1	60 Anti-dust cover
13	Gear box	1	37 Retaining ring	1	61 Screw
14	Packing	1	38 Bearing	1	62 Power cord
15	Bearing	1	39 Oil ring	1	63 Switch cord
16	2nd Shaft	1	40 Output shaft	1	64 Carbon brush cord
17	1st gear	1	41 P.T. screw	1	65 Spring washer
18	Bearing	2	42 Nylock bolt	4	66 Limit lever (down)
19	Gear case cover	1	43 Drum	1	67 Positioned screw
20	Hex bolt	6	44 Rope stopper	3	68 Cross screw
21	Hex bolt	1	45 Control ass'y	1	69 Return spring B
22	O-ring	1	46 Rubber packing	1	70 Return spring
23	Bearing	1	47 Housing cover	1	
24	3rd shaft	1	48 Hook	1	

►CWS-160/230/300

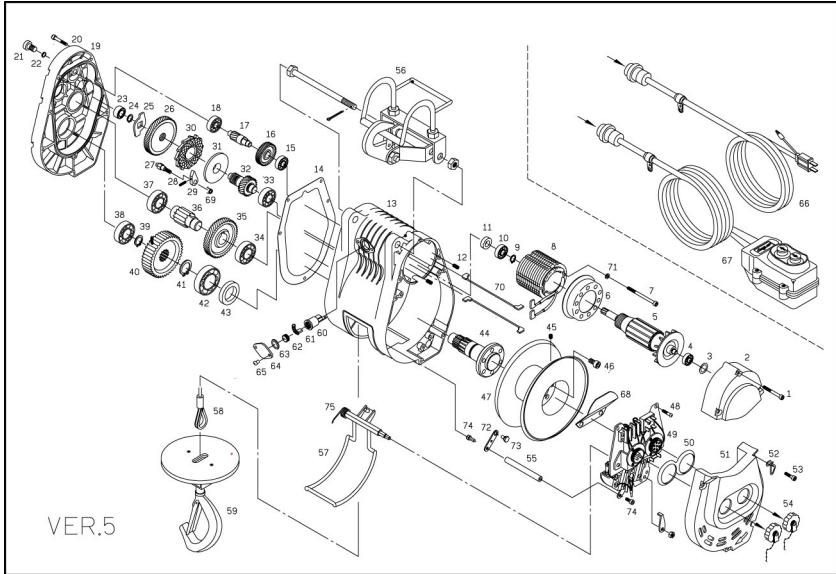

No.	Description	No.	Description	No.	Description			
1	Hex bolt	3	26	2nd gear	1	51	Housing cover	1
2	Motor rear cover	1	27	Set bolt	1	52	Hook	1
3	Washer	1	28	Spring	1	53	Hex bolt	4
4	Bearing	1	29	Pawl	1	54	Cap	2
5	Armature	1	30	Ratchet	1	55	Reverse winding shaft	1
6	Fan cover	1	31	Disk	1	56	Suspension hook ass'y	1
7	Hex bolt	2	32	3rd shaft	1	57	Limit lever (up)	1
8	Field coil	1	33	Bearing	1	58	Wire rope	1
9	Retaining ring	1	34	Bearing	1	59	Swivel hook	1
10	Bearing	1	35	3rd gear	1	60	Carbon holder	2
11	Oil ring	1	36	4th shaft	1	61	Carbon brush	2
12	Knob pin	2	37	Bearing	1	62	Brush cap	2
13	Gear box	1	38	Bearing	1	63	O-ring	2
14	Packing	1	39	Retaining ring	1	64	Brush cover	2
15	Bearing	1	40	4th gear	1	65	Screw	4
16	1st gear	1	41	Retaining ring	1	66	Power cord ass'y	1
17	2nd shift	1	42	Bearing	1	67	Switch cord ass'y	1
18	Bearing	1	43	Oil ring	1	68	Rope stopper	1
19	Gear case cover	1	44	Output shaft	1	69	Return spring	1
20	Hex bolt	6	45	P.T.screw	1	70	Carbon brush cord	1
21	Hex bolt	1	46	Hex bolt	6	71	Spring washer	2
22	O-ring	1	47	Drum	1	72	Limit lever (down)	1
23	Bearing	1	48	Screw	4	73	Positioned screw	1
24	Retaining ring	1	49	Control ass'y	1	74	Cross screw	2
25	Gear box fixture	1	50	Rubber packing	1	75	Return spring B	1

# Limited Warranty

This Limited Warranty is given by the COMEUP INDUSTRIES INC (the “Seller”) to the original purchaser (the “Purchaser”) of a **COMEUP Winch** specified in this manual. This Limited Warranty is not transferable to any other party.

The Seller takes the responsibility for all parts and components, with the exception of the wire rope, to be free from defects in materials and workmanship appearing under normal use for as long as the said Purchaser owns the vehicle that the winch was originally mounted on. Electrical components are warranted for 1 Year from date of purchase under the same conditions. Any **COMEUP Winch**, which is defective, will be repaired or replaced without charge to the Purchaser.

Upon discovering any defect, the Purchaser under this Limited Warranty is requested to return the complete winch and inform the seller or their authorised distributors of any claims. The Purchaser must provide a copy of the proof of purchase bearing the winch serial number, date of purchase, owners name and address, vehicle details and registration number.

The Limited Warranty does not cover any failure that results from improper installation, operation or the Purchaser’s modification in design. The winch is designed for vehicle self-recovery use only and should not be used in industrial applications or for moving people. The Seller does not warrant them to be suitable for such use.